



Series B . Models Bxx-P

Process meters

INDUSTRIAL SERIES . LARGE FORMAT METERS

Large format industrial meters for process signals in mA and Vdc. Different formats available with 60 mm and 100 mm digit height, 4 and 6 digits, in red or green color. Sturdy metal housing, with full IP65 protection, designed for panel, wall or hanging mount. Versatile and configurable, provides excitation voltage to power up the transducer, segment linearization, fast access to alarm setpoints, 'on power up' function, 'measure' function' and 5 configurable brightness levels. Universal AC and DC power. Accepts up to 3 output and control options (relays, analog retransmission, Modbus RTU, transistor outputs, RS-485 ASCII, ...). Configuration from frontal keypad or remote keypad.

1. Series B, models Bxx-P

Large format industrial meters for process signals

Large format meters for long distance reading, for industrial applications. Different formats available with 4 and 6 digits, with 60 mm and 100 mm digit height. Front keypad to access the configuration menu, and optional remote keypad.

Models to measure process signals in mA and Vdc. Provides excitation voltage configurable from +5 Vdc to +20 Vdc (max. 35 mA) to power up transducers. Scalable reading with selectable decimal point position.

Output and control options with 1, 2 and 3 relays, transistor outputs, controls for SSR relays, isolated analog outputs, communications in Modbus RTU, RS-485 ASCII and RS-232.

Sturdy metal housing with full IP65 protection. Internal connections by plug-in screw clamp terminals, and output through cable glands. Housing prepared for panel, wall and hanging mount.

- Configurable '**Fast access**' to selected functions with key 'UP' (▲) (*see section 1.12.11*)
- '**On power up**' for system protection on 'cold' start-up and / or activation of automatic tare (*see section 1.12.12*)
- up to 20 segments for signal linearization (*see section 1.12.8*)
- '**Field correction**' for fast and easy 'on the field' correction of offsets and signal drifts (*see section 1.12.3*)
- alarms with 1 or 2 setpoints, independent activation and deactivation delays, hysteresis, manual unlocking, ... (*see section 1.12.4*)
- '**Tare**' function for weight applications (*see section 1.12.14*)
- '**Peak & Hold**' for test break applications (*see section 1.12.9*)

Multiple display filters, memory of maximum and minimum reading, password protection, 5 brightness levels.

1.1 How to use this manual

If this is the first time you are configuring a Series B large format meter, below are the steps to follow to install and configure the instrument.

1. Identify the instrument format (*see section 1.4*)
2. Power and signal connections
 - open the instrument (*see section 1.5*)
 - connect the power (*see section 1.7*)
 - connect the signal and select jumper mA/Vdc (*see section 1.8*)
 - close the instrument (*see section 1.5*)
3. Configure the instrument (*see section 1.12*)
 - select the signal range, the decimal point position and scale the reading (*see section 1.12.2*)
4. Advanced configuration (optional)
 - configure the instrument alarms (*see section 1.12.4*)
 - configure the display filters (*see section 1.12.7*)
 - configure the fast access (*see section 1.12.11*)
 - configure the excitation voltage (*see section 1.12.15*)
 - configure other functions : segment linearization (*1.12.8*), 'on power up' (*1.12.12*), key 'LE' (*1.12.13*), tare (*1.12.14*), password (*1.12.16*)

Read all the manual sections in order to have a full and clear view of the characteristics of the instrument. Do not forget to read the installation precautions at section 1.17.

5. If the instrument includes analog output (AO) or serial communications (RTU, S4, S2)
 - to include an option to an instrument see section 1.6
 - to configure an installed option, access the option configuration menu (*see section 1.12.20*)
 - see section 2 for information regarding the output and control options available
6. Install the instrument
 - mount on panel, wall or hanging (*see section 1.16*)
 - adjust the brightness level according to your environmental needs (*see section 1.12.19*)

1.2 How to order

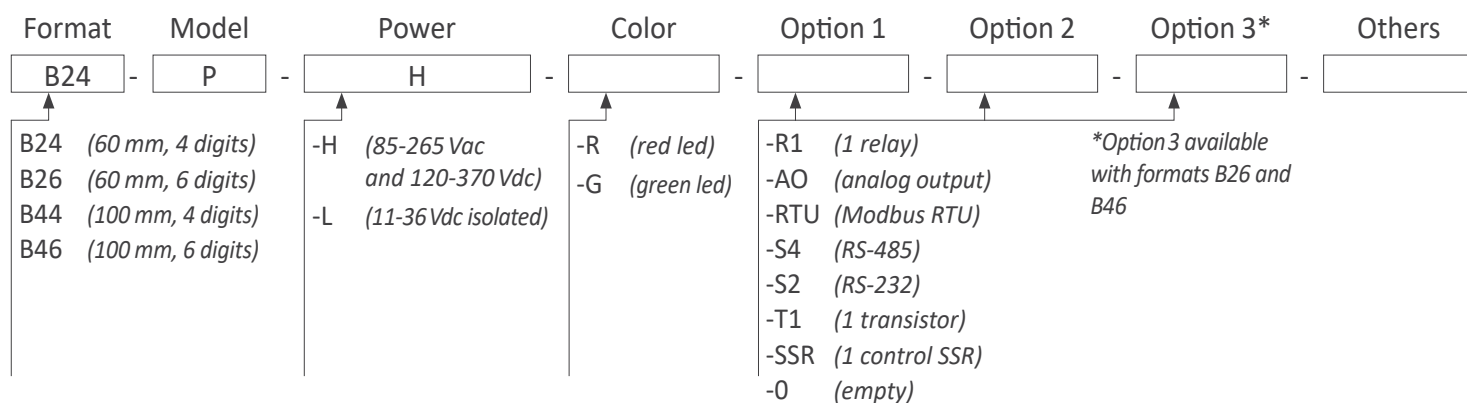

1.3 Index

1. Series B, models Bxx-P	2	1.12.14 'Tare' function	16
1.1 How to use this manual	2	1.12.15 Excitation voltage.	16
1.2 How to order	3	1.12.16 Password configuration	18
1.3 Index	3	1.12.17 Default factory configuration	18
1.4 Sizes and formats	4	1.12.18 Firmware version	18
1.4.1 Format B24.	4	1.12.19 Brightness configuration	18
1.4.2 Format B44.	4	1.12.20 Access to the options configuration menu	18
1.4.3 Format B26.	5	1.13 Factory configuration	19
1.4.4 Format B46.	5	1.14 Messages and errors	19
1.5 To access the instrument.	6	1.15 Full configuration menu.	20
1.6 Modular system.	6	1.16 Mounting.	22
1.7 Power connections and protective earth	7	1.17 Installation precautions	23
1.8 Input signal connections	7	1.18 Warranty	23
1.8.1 Connection examples	8	1.19 CE declaration of conformity	23
1.9 Connections for remote keypad	8	2. Output and control modules	24
1.10 Functions included	8	2.1 Module R1.	24
1.11 Technical specifications	9	2.2 Module T1	24
1.12 Configuration	10	2.3 Module SSR	25
1.12.1 How to operate the menus	10	2.4 Module AO	25
1.12.2 Initial set-up	11	2.5 Module RTU	26
1.12.3 Field correction	12	2.6 Module S4	26
1.12.4 Alarms	12	2.7 Module S2	27
1.12.5 Field correction menu	13	3. Other options and accessories	28
1.12.6 Alarms configuration menu	13	3.1 RKB - Remote keypad.	28
1.12.7 Display filters	14	3.2 Red LED	28
1.12.8 Segment linearization	14	3.3 Green LED	28
1.12.9 Display filters configuration menu	15		
1.12.10 Tools configuration menu	15		
1.12.11 Fast access	16		
1.12.12 'on power up' function.	16		
1.12.13 'LE' key	16		

1.4 Sizes and formats

1.4.1 Format B24

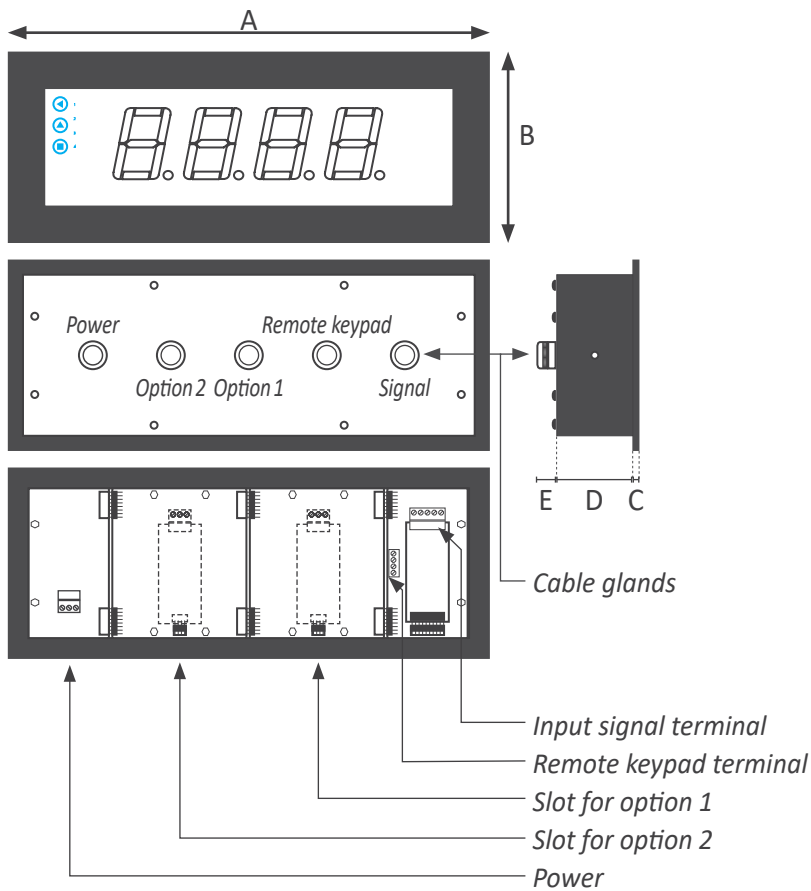

Size A	340 mm
Size B	135 mm
Size C	3 mm
Size D	55 mm
Size E	25 mm

Table 1 - Sizes B24

Cut-out G	322 mm (±1)
Cut-out F	117 mm (±1)

Table 2 - Panel cut-out B24

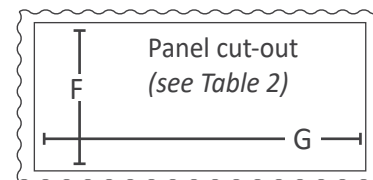

1.4.2 Format B44

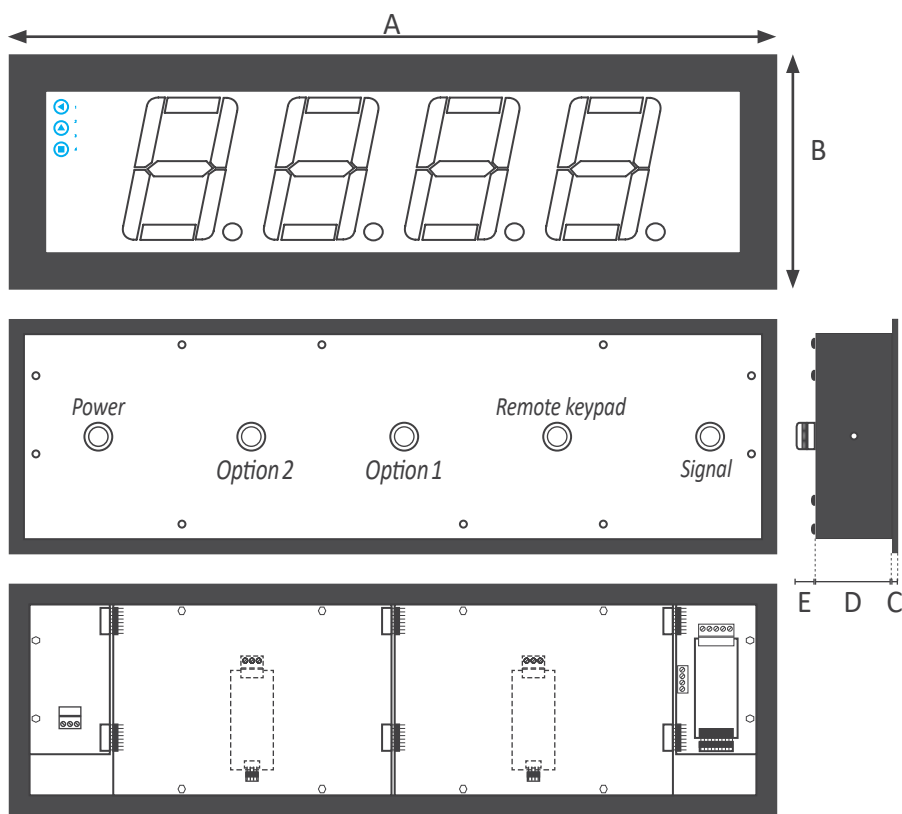

Size A	542 mm
Size B	166 mm
Size C	3 mm
Size D	55 mm
Size E	25 mm

Table 3 - Sizes B44

Cut-out G	524 mm (±1)
Cut-out F	148 mm (±1)

Table 4 - Panel cut-out B44

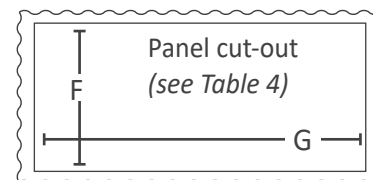

1.4.3 Format B26

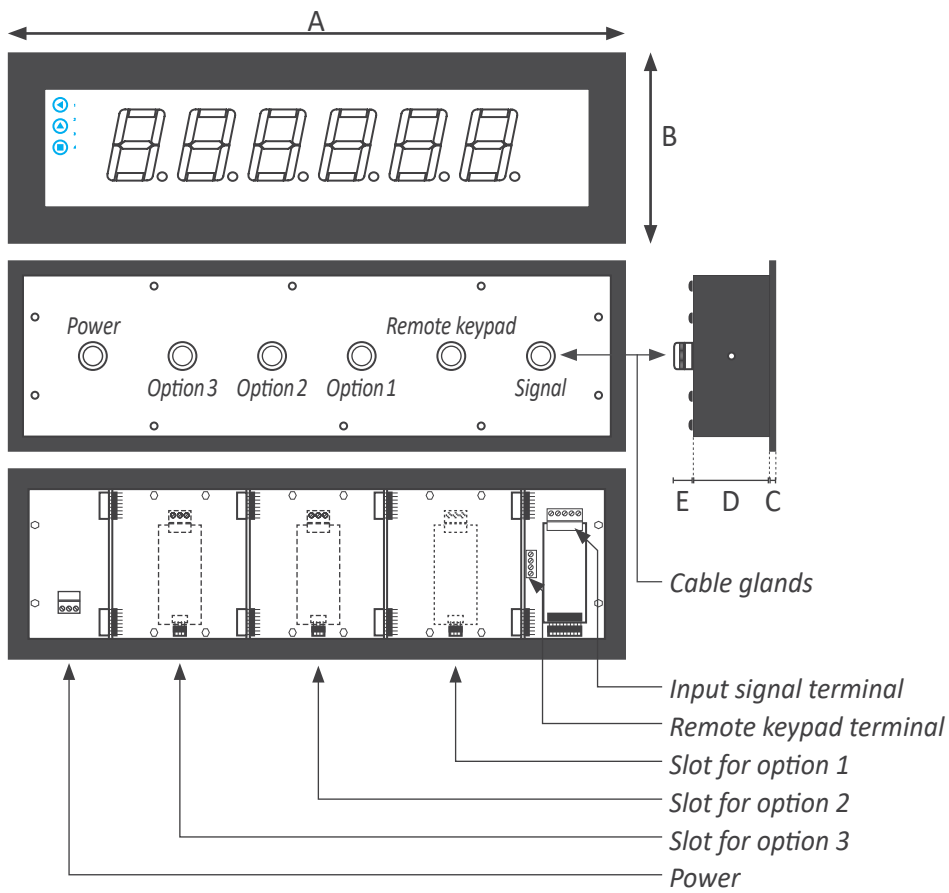

Size A	436 mm
Size B	135 mm
Size C	3 mm
Size D	55 mm
Size E	25 mm

Table 5 - Sizes B26

Cut-out G	418 mm (±1)
Cut-out F	117 mm (±1)

Table 6 - Panel cut-out B26

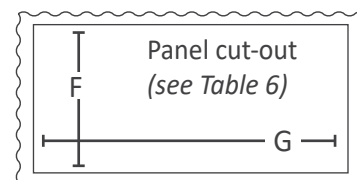

1.4.4 Format B46

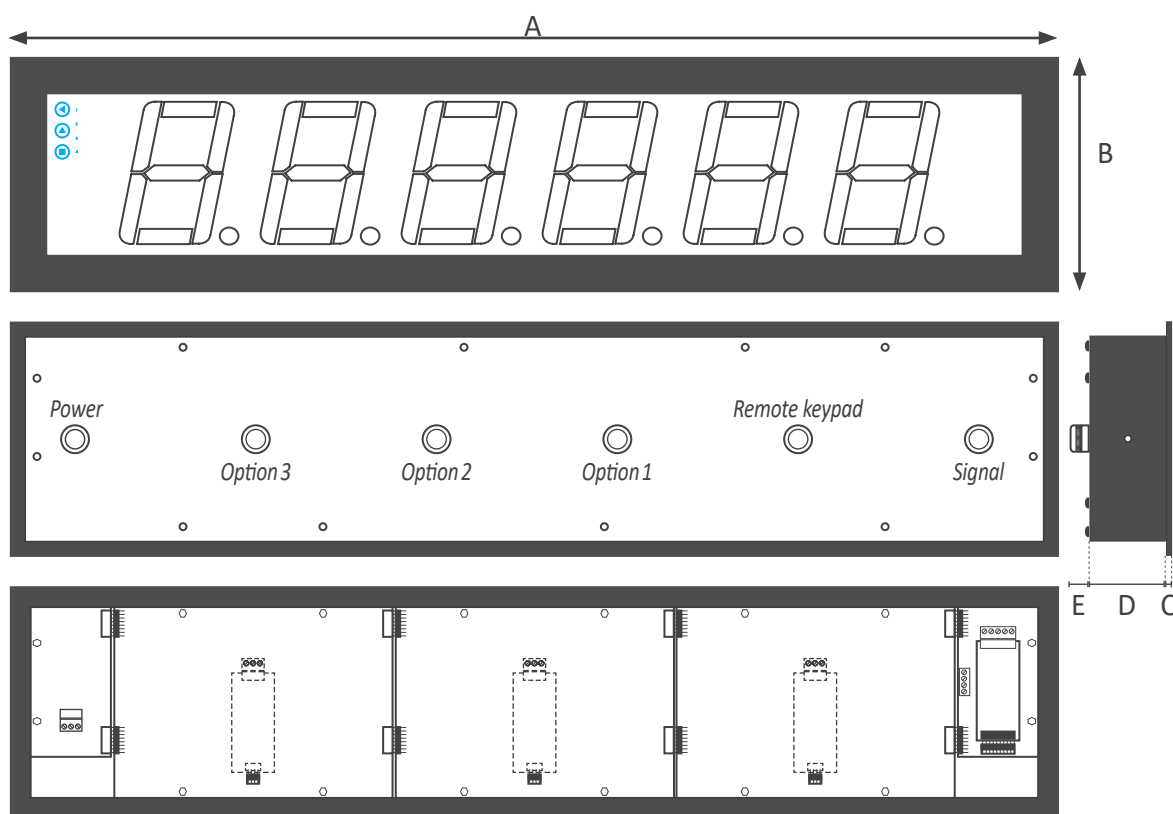

Size A	740 mm
Size B	166 mm
Size C	3 mm
Size D	55 mm
Size E	25 mm

Table 7 - Sizes B46

Cut-out G	722 mm (±1)
Cut-out F	148 mm (±1)

Table 8 - Panel cut-out B46

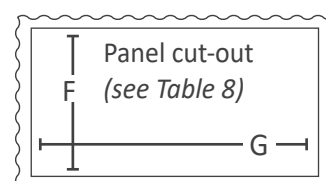

1.5 To access the instrument

To open the housing, remove the screws from the back cover. With each screw there is a metal washer and a plastic washer. Once the screws are out, remove the back cover.

The figure below shows the instrument internal structure for a B26 format. It shows the location of the 3 slots for optional output and control modules, the power terminal and the input signal terminal.

To close the instrument, place the back cover, the screws, the metal washer and the plastic washer. The plastic washer is in contact with the back cover. Confirm that the screws are correctly turning inside the internal female screws.

To ensure a correct IP65 protection tighten the back cover screws with a strength between 30 and 40 Ncm, with the help of a dynamometer screwdriver.

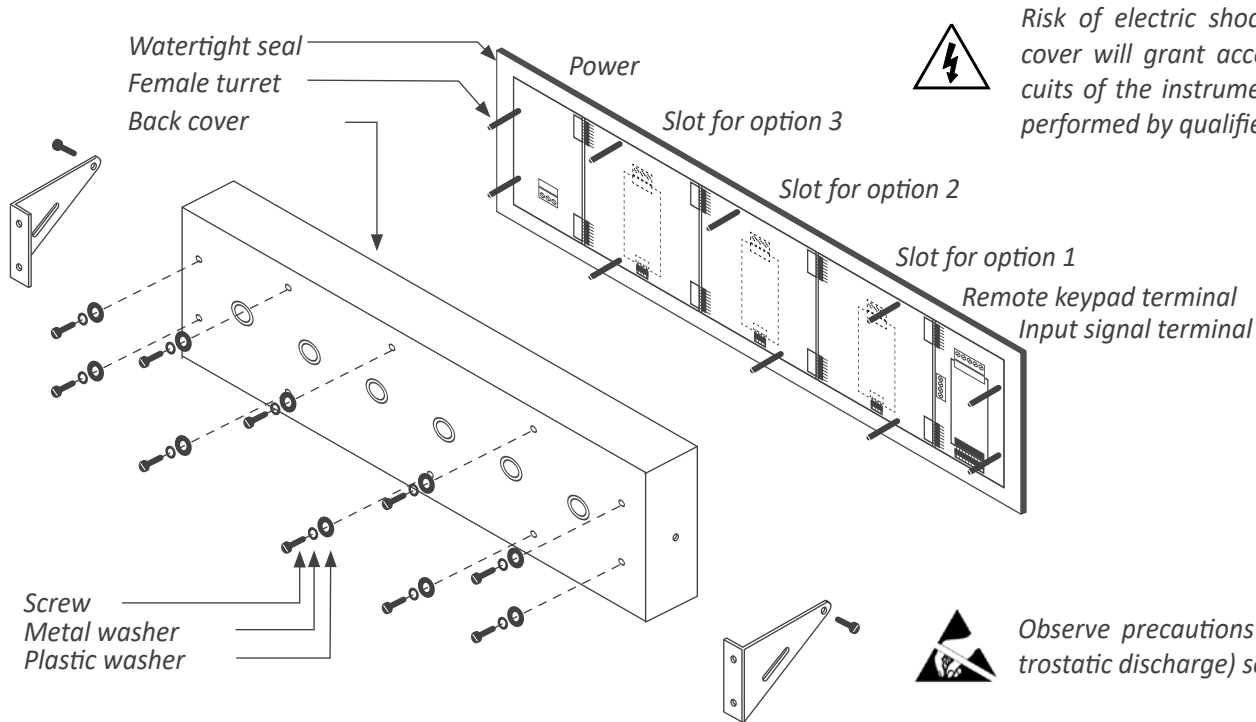

1.6 Modular system

Large format meters from Series B are designed with an internal modular architecture. The output and control modules are independent and can be installed by accessing the internal circuits of the instrument, and connecting the module to the connection jumpers of the selected slot.

Each module is provided with a cable tie to fix the module to the tie base. The input signal modules defines the instrument function and are exchangeable, switching a temperature meter to an impulse counter only by replacing the input signal module.

See section 2. for information regarding the output and control options available

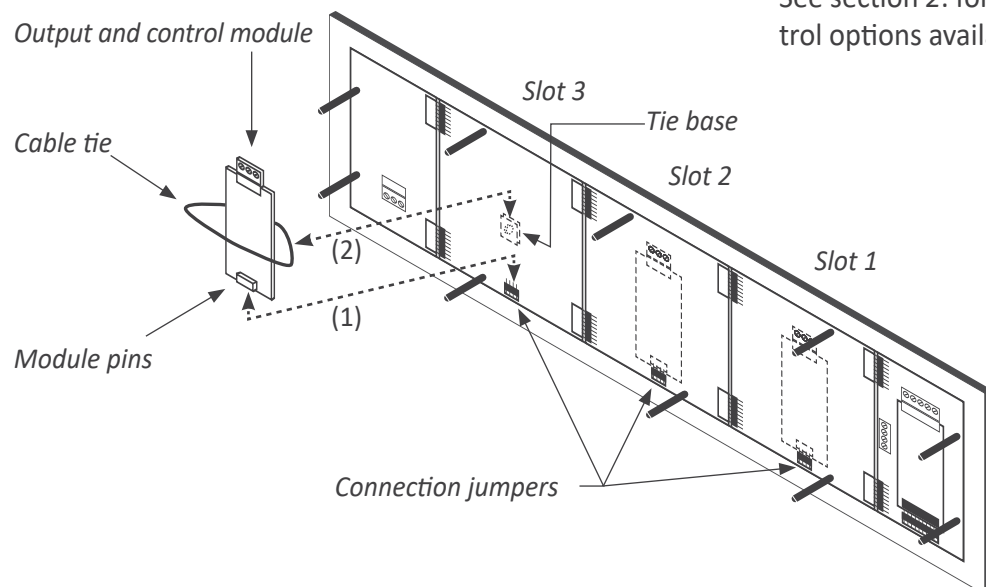

- To install an output and control module
- (1) insert the 'module pins' into the 'connection jumpers' in one of the free slots
 - (2) place the 'cable tie' into the 'tie base' and embrace the 'module' firmly, until it is fixed

1.7 Power connections and protective earth

1. Unscrew the screws from the back cover and remove the back cover (see section 1.5).
2. Pass the power cable through the power cable gland (see section 1.4).
3. Prepare the power cables so that the earth wire is 20 cm longer than the other cables (see Figure 1).

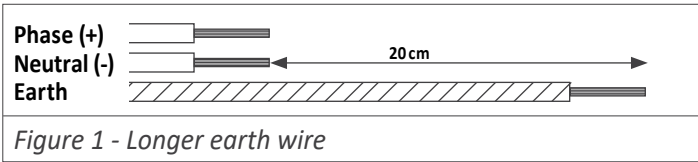

Figure 1 - Longer earth wire

4. Connect the earth wire to the internal fixed screw 'PE' (see Figure 2) located at the inside of the back cover. The instrument internally connects the back cover metallic

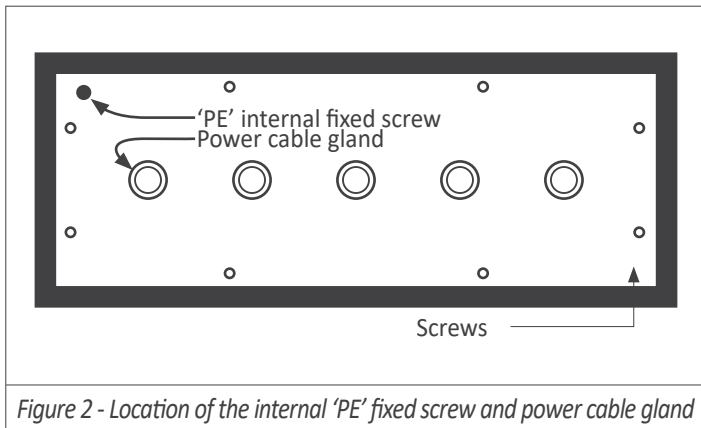

Figure 2 - Location of the internal 'PE' fixed screw and power cable gland

5. Connect phase and neutral (in AC power) or positive and negative (in DC power) to the internal power terminal.
6. The connections label attached to the outside of the instrument has some free space left to write the color or local code for each cable.
7. To comply with security regulation 61010-1, add to the power line a protection fuse acting as a disconnection element, easily accessible to the operator and identified as a protection device.

Power 'H'	500 mA time-lag fuse
Power 'L'	1000 mA time-lag fuse

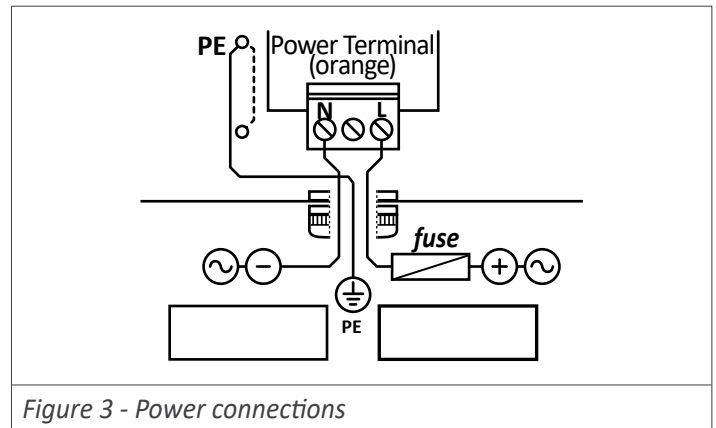
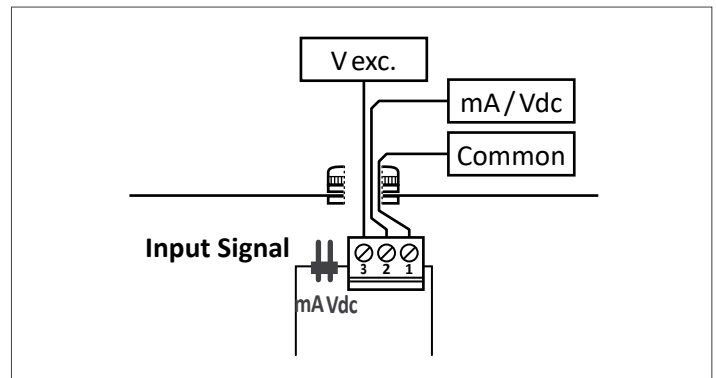

Figure 3 - Power connections

1.8 Input signal connections

1. Unscrew the screws from the back cover and remove the back cover (see section 1.5).
2. Locate the input signal terminal (see section 1.4). For signal connection examples see section 1.8.1
3. Pass the signal cable through the signal cable gland (see section 1.4).
4. Connect the input signal cables (see Figure 4) and select the appropriate jumper 'mA' or 'Vdc'.
5. The connections label attached to the outside of the instrument has some free space left to write the color or local code for each cable.



mA/Vdc	Input signal in mA or Vdc
Vexc	Excitation voltage to power the transducer
Common	
Jumper mA	Close for mA signals (and open Vdc)
Jumper Vdc	Close for Vdc signals (and open mA)

Figure 4 - Signal connections

1.8.1 Connection examples

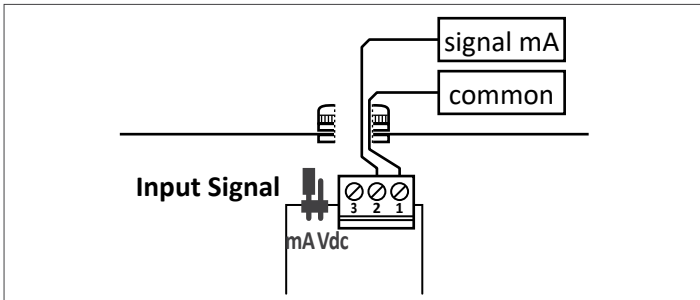

Figure 5 - Connections for active 4/20 mA signals (or ±20 mA)

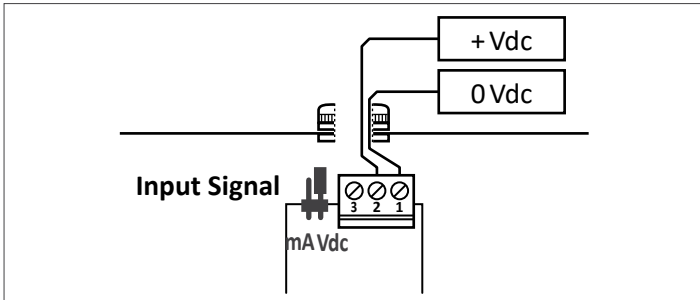

Figure 6 - Connections for active 0/10 Vdc signals (or ±10 Vdc)

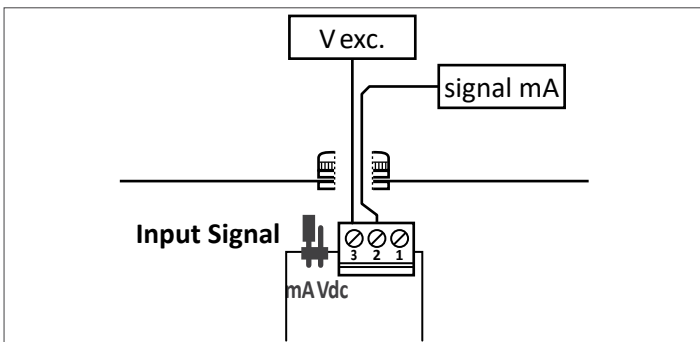

Figure 7 - Connections for passive 4/20 mA signals (or ±20 mA)

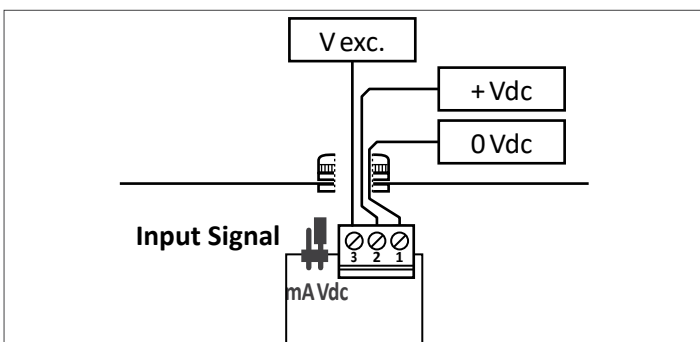
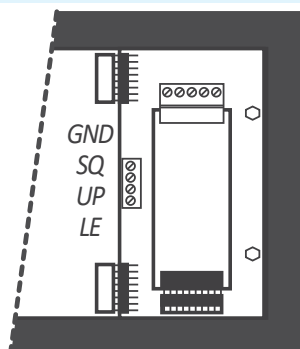

Figure 8 - Connections for passive 0/10 Vdc signals (or ±10 Vdc)

1.9 Connections for remote keypad

The 4 pin terminal located beside the input signal module allows to replicate a remote version of the front keypad. Connect 4 cables for front keys 'SQ' (■), 'UP' (▲) and 'LE' (◀) and for the common. Pass these cables through the 'remote keypad' cable gland (see section 1.4).



1.10 Functions included

Functions included		Section
Fast access menu	yes, configurable	1.12.11
Segment linearization	up to 20 segments	1.12.8
Display filters	recursive 'steps' fixed digits left zeros	1.12.7
'On Power Up'	yes	1.12.12
Excitation voltage	configurable	1.12.15
'Measure'	yes	1.12.11
Alarms	simple or double setpoint activation delays deactivation delays hysteresis inverted relays locked alarms	1.12.4
Field correction	yes, for high and low signals	1.12.3
'Peak & Hold'	yes	1.12.7
Tare function	yes	1.12.14
Memory	maximum, minimum	1.12.11
Password	configuration locked	1.12.16
Brightness	configurable, 5 levels	1.12.19

Table 9 - Functions included

1.11 Technical specifications

Digits		Power	
number of digits	4 or 6 (see Table 10)	power 'H'	85 to 265 Vac and 120 to 370 Vdc isolated (isolation 2500 Vac)
digit	7 segments	power 'L'	11 to 36 Vdc isolated (isolation 1500 Vdc)
view angle	120°	consumption	(see Table 10)
color	red or green	fuses	(see section 1.7)
digit height	(see Table 10)	wire section	max. 2.5 mm ²
Reading		Configuration	
max., min.	(see Table 10)	front keypad with 3 keys	remote keypad (see section 3.1)
decimal point	configurable	Output and control options	
overrange / underrange	flash reading	relay output, analog retransmission, Modbus RTU, ... (see section 2)	
acquisitions	(see Table 10)	Mechanical	
display refresh	(see Table 10)	IP protection	full IP65 housing
step response	(see Table 10)	mounting	panel, wall , hanging (see section 1.16)
Input signal		connections	cable gland outputs
signal ranges	4/20 mA, ±20 mA 0/10 Vdc, ±10 Vdc	housing material	internal plug-in screw terminals
maximum oversignal	100 mA or 100 Vdc	weight	textured iron, black painted
input impedance	11 R en mA, 932 K en Vdc	front sizes	methacrylate front filter (see Table 10)
accuracy	0.05 % o 0.03 % (see Table 10)	panel cut-out depth	(see section 1.4)
thermal drift offset	10 ppm / °C	depth	(see section 1.4)
thermal drift span*	25 ppm / °C (*included offset thermal drift)	Temperature	
wire section	max. 0.5 mm ²	operation	from 0 to +50 °C
Excitation voltage		storage	from -20 to +70 °C
voltage output	+20 Vdc, +15 Vdc, +10 Vdc, +5 Vdc selectable by menu	warm-up time	15 minutes
accuracy	±5 %		
maximum current	35 mA		
protection	against short circuit		

	Format B24	Format B44	Format B26	Format B46
Number of digits	4	4	6	6
Digit height	60 mm	100 mm	60 mm	100 mm
Reading distance	25 meters	50 meters	25 meters	50 meters
Accuracy (% F.S.)	0.05 %	0.05 %	0.03 %	0.03 %
Acquisitions/second	15	15	3.5	3.5
Refresh/second	15	15	3.5	3.5
Step response (0% to 99% of signal)	120 mSec.	120 mSec.	300 mSec.	300 mSec.
Slots for output and control options	2	2	3	3
Maximum / minimum reading	9999 / -1999		999999 / -199999	
Consumption (without options installed)	3 W	5.25 W	3.5 W	5.5 W
Consumption (with options installed)	5 W	6.75 W	5,5 W	7 W
Weight	2200 gr.	2500 gr.	3500 gr.	4500 gr.

Table 10 - Technical specifications associated to format

1.12 Configuration

1.12.1 How to operate the menus

The instrument has two menus accessible to the user :

‘*Configuration menu*’ (key ‘SQ’) (■)

‘*Fast access*’ menu (key ‘UP’) (▲)

Configuration menu

The ‘*configuration menu*’ modifies the configuration parameters to adapt the instrument to the application needs. To access the ‘*configuration menu*’ press for 1 second the ‘SQ’ (■) key. This access can be blocked by activating the ‘**Pass-word**’ (‘PASS’) function. While operating the ‘*configuration menu*’, the alarm status is ‘hold’ to the status it had before accessing the menu, and the output and control modules remain in ‘*error*’ state. When leaving the ‘*configuration menu*’, the instrument applies a system reset, followed by a brief disconnection of the alarms and the output and control modules. Functionality is then recovered.

For a detailed explanation on the ‘*configuration menu*’ see the following sections, and for a full view of the ‘*configuration menu*’ see section 1.15.

‘Fast access’ menu

The ‘*fast access*’ menu is an operator configurable menu, providing fast and direct access to the most usual functions of the instrument with a single key pad stroke. Press key ‘UP’ (▲) to access this menu.

See section 1.12.11 for a list of selectable functions for the ‘*fast access*’ menu in this instrument. The ‘**Password**’ (‘PASS’) function does not block access to this menu. Accessing and modifying parameters in the ‘*fast access*’ menu does not interfere with the normal functionality of the instrument, and it does not generate any system reset when validating the changes.

Operating with the front keypad inside the menus

Key ‘SQ’ (■) - press the ‘SQ’ (■) key for 1 second to access the ‘*configuration menu*’. Inside the menu, the ‘SQ’ (■) key acts as an ‘ENTER’. It enters into the menu option selected, and when entering a numerical value, it validates the number.

Key ‘UP’ (▲) - press the ‘UP’ (▲) key to access the ‘*fast access*’ menu. Inside the menu, the ‘UP’ (▲) key sequentially moves through the available parameters and menu entries. When entering a numerical value, it modifies the digit selected by increasing its value to 0, 1, 2, 3, 4, 5, 6, 7, 8, 9.

Key ‘LE’ (◀) - press the ‘LE’ (◀) key to activate the configured special functions associated to this key. Inside the menu, the ‘LE’ (▲) acts as an ‘ESCAPE’. It leaves the selected menu level and eventually, by leaving all menu levels, it leaves from the configuration menu. Then changes are applied and the instrument is back to normal function. When entering a numerical value, it selects the active digit, and the value is then modified by key ‘UP’ (▲).

‘Rollback’

After 30 seconds without interaction from the operator, the instrument will rollback and leave the ‘*configuration menu*’ or the ‘*fast access*’ menu. All changes will be discarded.

Instruments with 4 and 6 digits

The configuration menus included in this document show values for a 6 digit instrument. In case of 4 digit instruments, note that maximum reading values should be 9999 instead of 999999 to 9999 and minimum reading values should be -1999 instead of -199999.

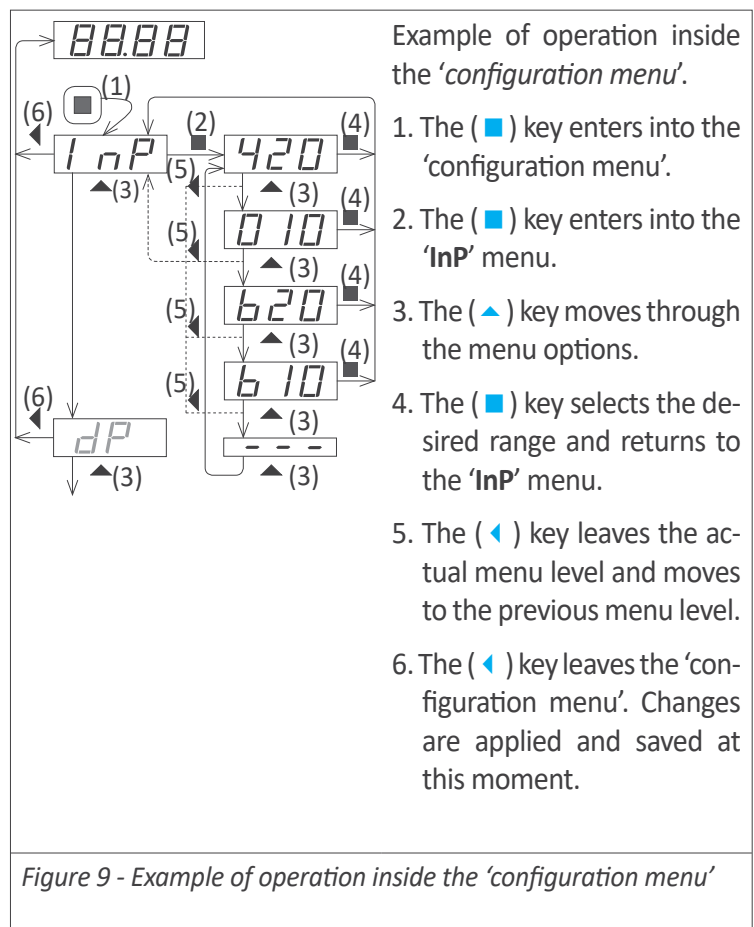
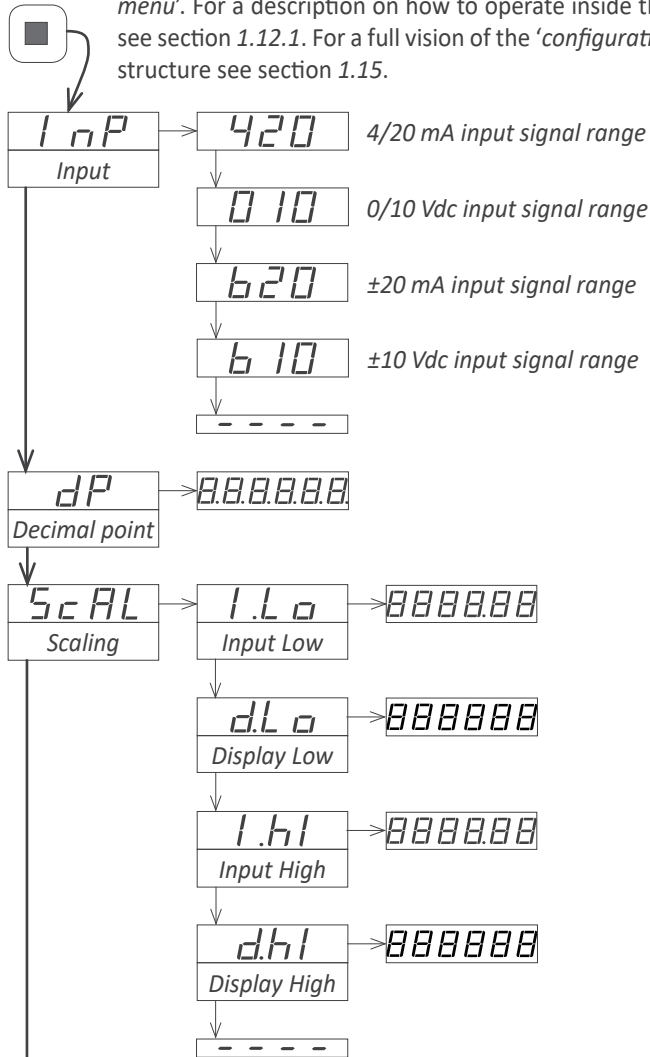

Figure 9 - Example of operation inside the ‘*configuration menu*’

1.12.2 Initial set-up

Press 'SQ' (■) for 1 second to access the 'configuration menu'. For a description on how to operate inside the menus see section 1.12.1. For a full vision of the 'configuration menu' structure see section 1.15.



To configure the initial set up of the instrument, select the input signal range, the decimal point position, and scale the reading.

At the 'Input' ('Inp') parameter, select the input signal range.

- select '420' for 4/20 mA signals. Close the 'mA' jumper (see section 1.8). It accepts active and passive signals. See connections at section 1.8.1.
- select '010' for 0/10 Vdc signals. Close the 'Vdc' jumper (see section 1.8). It accepts active and passive signals. See connections at section 1.8.1.
- select 'b20' for ±20 mA signals. Close the 'mA' jumper (see section 1.8). It accepts active and passive signals. See connections at section 1.8.1.
- select 'b10' for ±10 Vdc signals. Close the 'Vdc' jumper (see section 1.8). It accepts active and passive signals. See connections at section 1.8.1.

At the 'Decimal point' ('dP') parameter, select the decimal point position. Move the decimal point with the 'LE' (◀) key.

At the 'Scaling' ('ScAL') menu, configure the reading for the input signal range selected. The parameters are:

- at the 'Input Low' ('I.Lo') parameter configure the low input signal, in mA or Vdc, with two decimals.
- at the 'Display Low' ('d.Lo') parameter configure the reading associated to the low input signal configured before.
- at the 'Input High' ('I.hI') parameter configure the high input signal, in mA or Vdc, with two decimals.
- at the 'Display High' ('d.hI') parameter configure the reading associated to the high input signal configured before.

Range	Input Low ('I.Lo')	Display Low ('d.Lo')	Input High ('I.hI')	Display High ('d.hI')
4/20 mA	4.00 mA	0	20.00 mA	1000
0/10 Vdc	0.00 Vdc	0	10.00 Vdc	1000
±20 mA	-20.00 mA	-1000	20.00 mA	1000
±10 Vdc	-10.00 Vdc	-1000	10.00 Vdc	1000

Table 11 - Scaling parameter default values for each signal range

1.12.3 Field correction

The 'Field correction' ('F.cor') function corrects the instrument reading once installed on the field. Reading offsets and deviations can occur due to inaccuracies on the real signal. The 'field correction' function offers a fast and easy way to compensate for this inaccuracies.

Generate the low input signal and if the reading is not as desired, activate the 'low level' field correction function. The instrument will configure itself so that with the actual input signal, the reading is as indicated at the 'd.Lo' parameter. Field correction can be applied to the low input signal and to the

high input signal.

Example: a 0/10 Bar pressure transmitter provides a 4/20 mA output signal. At installation, the operator detects that the reading at 0 Bar is 0.34 Bar and that at 10 Bar the reading is 10.72 Bar.

Apply the 'Field correction' / 'F.Lo' function while reading is 0.34 Bar and the instrument will automatically correct the reading to 0.00 Bar. Afterwards, apply the 'Field correction' / 'F.Hi' function while reading is 10.72 Bar and the instrument will automatically correct the reading to 10.00 Bar.

1.12.4 Alarms

The instrument manages 3 independent internal alarms, each one controlling the activation of an optional relay, transistor or control SSR output.

Optional modules (see section 2) are installed at the free slots inside the instrument (see section 1.4). B24 and B44 formats have 2 free slots for output and control modules, while B26 and B46 formats have 3 free slots for output and control modules.

The instrument has 3 front leds that reflect the state of the 3 internal alarms. These leds are only for local help during installation, as they are not appropriate for long distance reading.

Each alarm controls the activation of the relay, transistor or control SSR installed on its associated slot, and the front led.

- **Configurable parameters**

Each alarm has several parameters for configuration, starting with the usual setpoint, hysteresis and maximum (alarm

active when reading is higher than setpoint) or minimum (alarm active when reading is lower than minimum) alarm types (see Figure 10).

- **Activation and deactivation delays**

Each alarm can configure independent activation and deactivation delays. These delays affect the alarm as a whole, and the delay will affect the front led and the associated relay.

- **Second setpoint**

Configuring a second setpoint creates 'windowed alarms'. The windowed alarm controls with a single relay output if the reading is inside or outside the values defined (see Figure 11).

- **Inverted relay**

Activate the 'inverted relay' function to invert the activation logic of the associated relay.

- **'Locked alarms'**

Activate the 'locked alarms' function will force the operator to interact with the instrument when an alarm has been activated. Once activated, the alarm will remain locked at active state, even if the reading returns to a value below setpoint, until the operator manually unlocks the alarms pressing the front key 'LE' (or the remote key 'LE', see section 3.1).

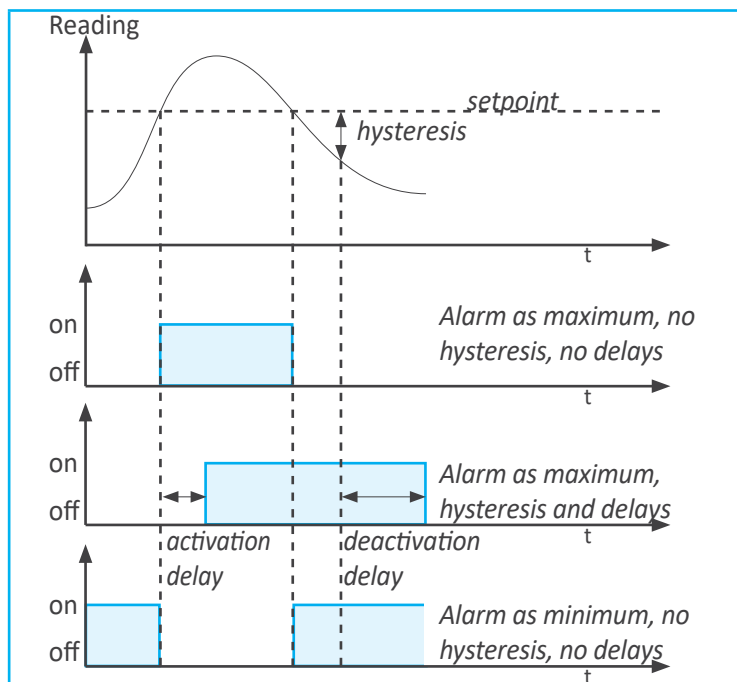

Figure 10 - Examples of alarm with 1 setpoint

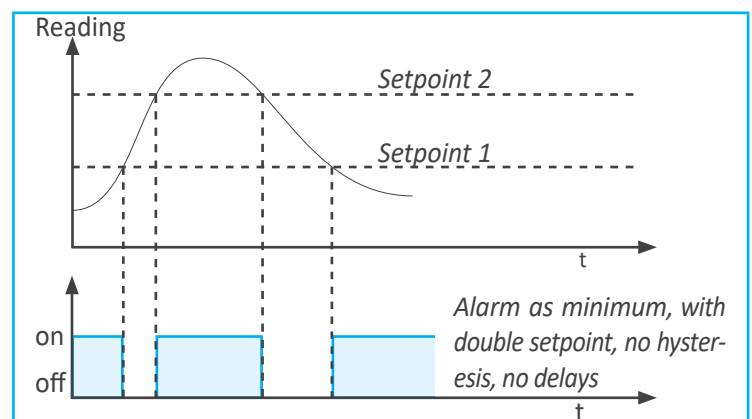
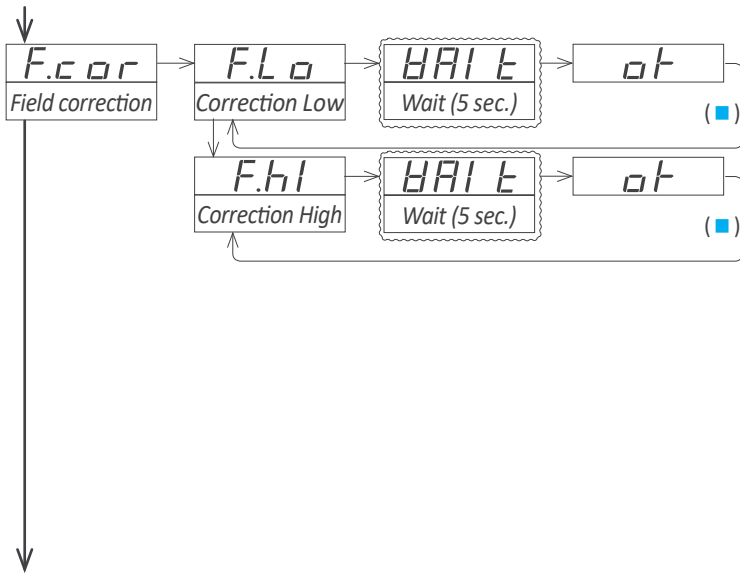

Figure 11 - Example of alarm with 2 setpoints

1.12.5 Field correction menu



To operate the 'Field Correction' ('F.cor') function for the offset, generate the low input signal and access the 'Field Low' ('F.Lo') function. The instrument starts the correction process:

- message with the measurement type ('mA' or 'Vdc')
- message 'wait' ('WAIT') in flash mode
- after 5 seconds, message 'ok' ('OK')
- at this point, press key 'SQ' (■)
- the menu returns to menu entry 'Field Low' ('F.Lo')

The instrument has read the input signal value and automatically applies the value to the 'Input Low' ('I.Lo') parameter.

For the high signal, repeat the process generating the high input signal and access the 'Field High' ('F.hi') function. The instrument reads the input signal value and automatically applies the value to the 'Input high' ('I.hi') parameter.

1.12.6 Alarms configuration menu

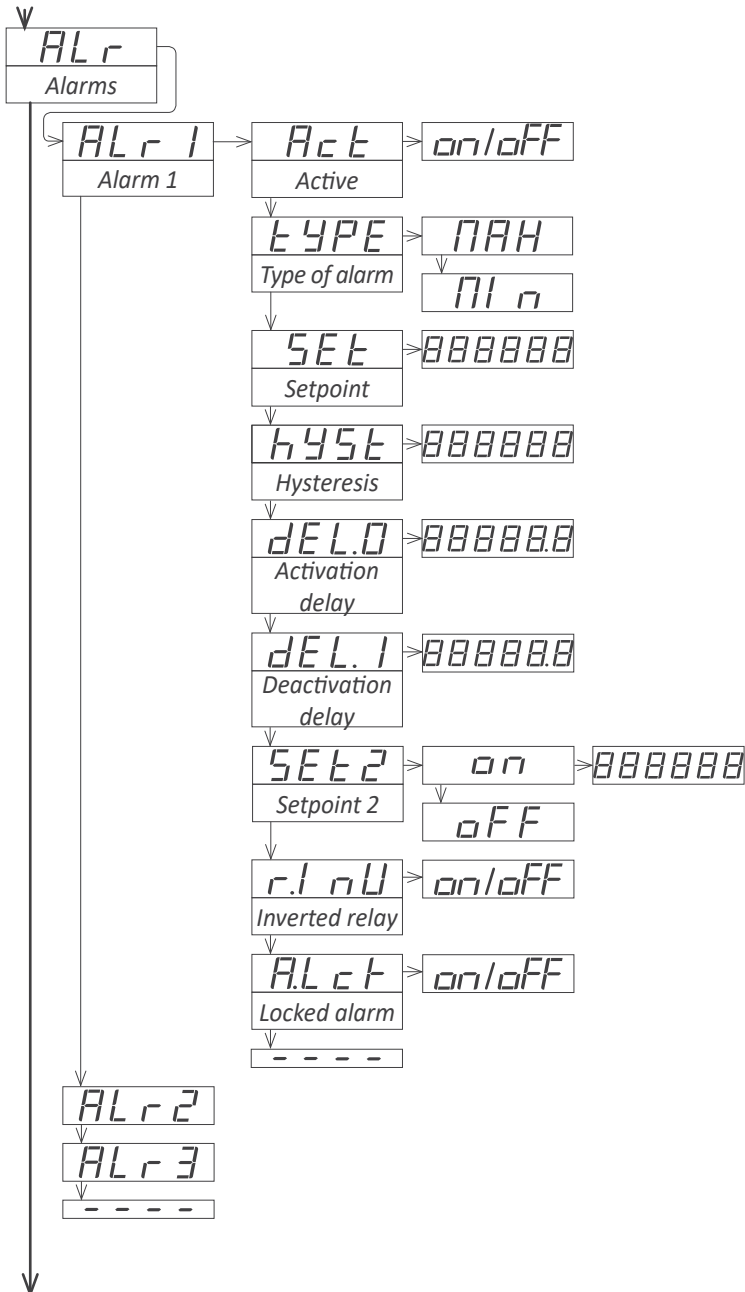

To configure the alarm, access the alarm menu ('ALr1', 'ALr2' or 'ALr3') and configure the following parameters :

- at the 'Active' ('Act') parameter select 'on'
- at the 'Type of alarm' ('TypeE') parameter select 'MAX' for maximum alarm (activates when reading is higher than setpoint), or 'Min' for minimum alarm (activates when reading is lower than setpoint).
- at the 'Setpoint' ('SEt') parameter configure the alarm activation point. Parameter value is accessible through 'fast access' (see section 1.12.11).
- at the 'Hysteresis' ('hySt') parameter select the hysteresis value. Hysteresis applies to the alarm deactivation. Alarm deactivates once the reading is beyond the setpoint plus the hysteresis value. Hysteresis prevents relay switching in case of signal fluctuations close to the setpoint value.
- at the 'Activation delay' ('dEL.0') parameter configure the delay to apply before the alarm is activated. Delay starts to count once the setpoint is reached. Value from 0.0 to 99.9 seconds.
- at the 'Deactivation delay' ('dEL.1') parameter configure the delay to apply before the alarm is deactivated. Delay starts to count once the setpoint is reached plus the hysteresis value. Value from 0.0 to 99.9 seconds.
- to work with 'windowed alarms' (see Figure 11) activate 'Setpoint 2' ('SEt2') to 'on' and then configure the desired second setpoint value. Second setpoint must always be higher in value than the first setpoint.
- at the 'Inverted relay' ('r.InV') parameter select 'on' to invert the activation logic of the relay. Relay is inactive when alarm is active, and relay is active when alarm is inactive.
- at the 'Locked alarm' ('A.Lck') parameter select 'on' to block the automatic alarm deactivation. Alarm deactivation must be performed manually, by pressing the 'LE' front button (see section 1.12.13).

1.12.7 Display filters

The instrument provides several functions to personalize the reading of the instrument, in order to stabilize the measure and minimize the signal noise. The available functions are:

- the **'Fixed Digits'** (**'FIX.d'**) allows to fix each digit to a fixed value. Usually one or more digits to the right are fixed to '0'. To fix a digit, all digits to its right must be also fixed. Value '-' means that the digit is not fixed.
- the **'Average filter'** (**'AVr'**) applies a recursive filter to the reading function, in order to reading oscillations due to noisy signals.
- the **'Steps'** (**'StEP'**) function defines the reading to be done in steps of 1, 2, 5, 10, 20 or 50 counts.

Example - selecting a step of 20 configures the reading to change in steps of 20 counts ('1420', '1440', '1460', ...).

- the **'Left Zero'** (**'LZEr'**) function lights all zeros to the left.
- the **'Memory of maximum'** (**'MAX'**) function displays the maximum reading value stored in memory and allows to reset this value. This parameter is directly accessible using key 'UP' (▲) (see section 1.12.11).
- the **'Memory of minimum'** (**'MIn'**) function displays the minimum reading value stored in memory and allows to reset this value. This parameter is directly accessible using key 'UP' (▲) (see section 1.12.11).

- the **'Peak & hold'** (**'P.hLd'**) function visualizes and holds the maximum reading. For test-break applications, where the meter always increases its value until the unit under test breaks and the signal falls down. The meter maintains the maximum reading before the signal fell down. Press any front key to free the reading or configure automatic release of the reading after a predefined time.

To free the 'hold' reading, press any of the front key pad or wait the time configured at the **'time'** parameter.

Time 0	hold disabled ('Off')
Time 1 a 3999	seconds waiting
Time 4000	infinite hold

While 'hold' is active, the instrument alarms are still associated to the input signal, therefore still providing control to disconnect the application once the test has finished.

Example: to test a container, a fluid under pressure is inserted into the container. A pressure transducer provides a 4/20 mA proportional to the pressure applied. When the container breaks, the measured pressure drops sharply. The 'Peak&Hold' function retains the maximum reading on display.

1.12.8 Segment linearization

The instrument provides a segment linearization function that allows up to 20 segments to linearize non linear signals.

Example: a tank with a non regular shape is used for water storage. The tank has a pressure transducer, and it provides a signal proportional to the level of water in the tank. Using the segment linearization function the reading can be scaled to provide information related to the volume of water in the tank, instead of the height of water in the tank.

The operator needs to define the number of segments to be used, between 2 and 20. Then the operator must define the signal and reading value for each of the points. Once all the points are entered, activate the linearization and the instrument will check the consistency of the data entered.

If the instrument detects problems with the data introduced, an error message will appear together with the point were

the error was found. The function will not be activated until all errors have been solved.

The configuration can be erased activating the function 're-set'.

1.12.9 Display filters configuration menu

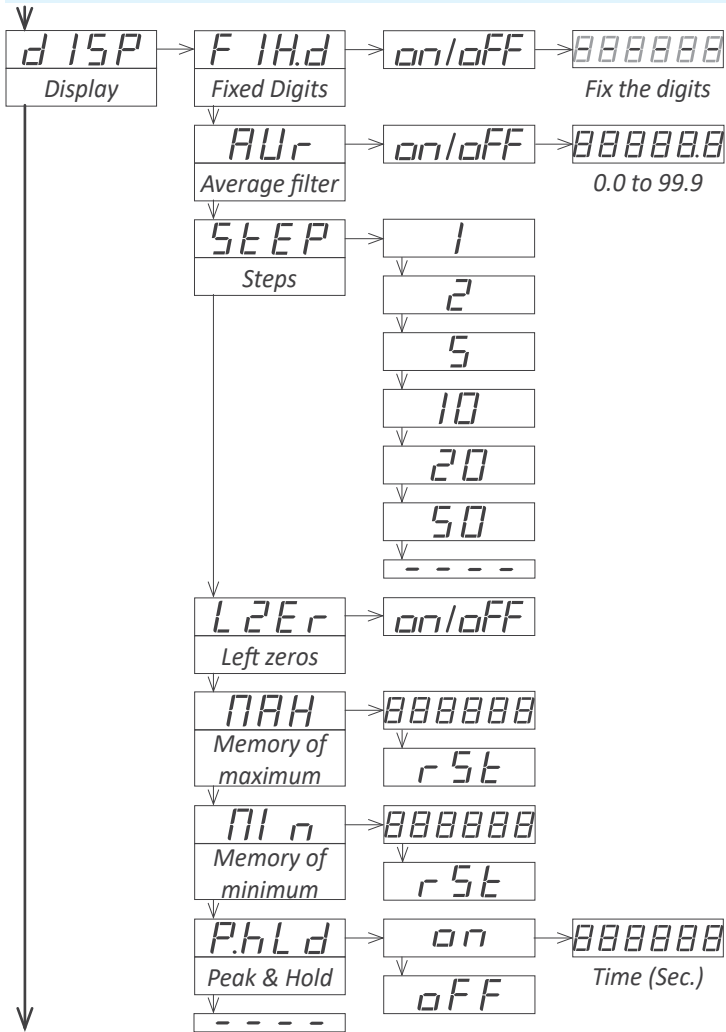

All display functions are grouped under the 'Display' menu. For more information relating the functions listed below see section 1.12.7.

- at the 'Fixed Digits' ('FIX.d') parameter, fix the digits to a fixed value. The '-' value means that the digit is not fixed.
- at the 'Average filter' ('Avr') parameter select 'on' and configure the filter strength between '0.0' and '99.9'. Higher values activate stronger filter. Stronger filters slow down the reading changes.
- at the 'Steps' ('StEP') parameter configure the value for the steps reading changes.
- at the 'Left Zeros' ('LZE') parameter select 'on' to activate the left zeros.
- the 'Memory of maximum' ('MAX') and 'Memory of minimum' ('MIN') are access to the memory values. To reset the value, select the 'rSt' entry and press 'SQ' (■).
- at the 'Peak & hold' ('P.hLd') menu select 'on' to activate the function and configure the 'hold' time.

1.12.10 Tools configuration menu

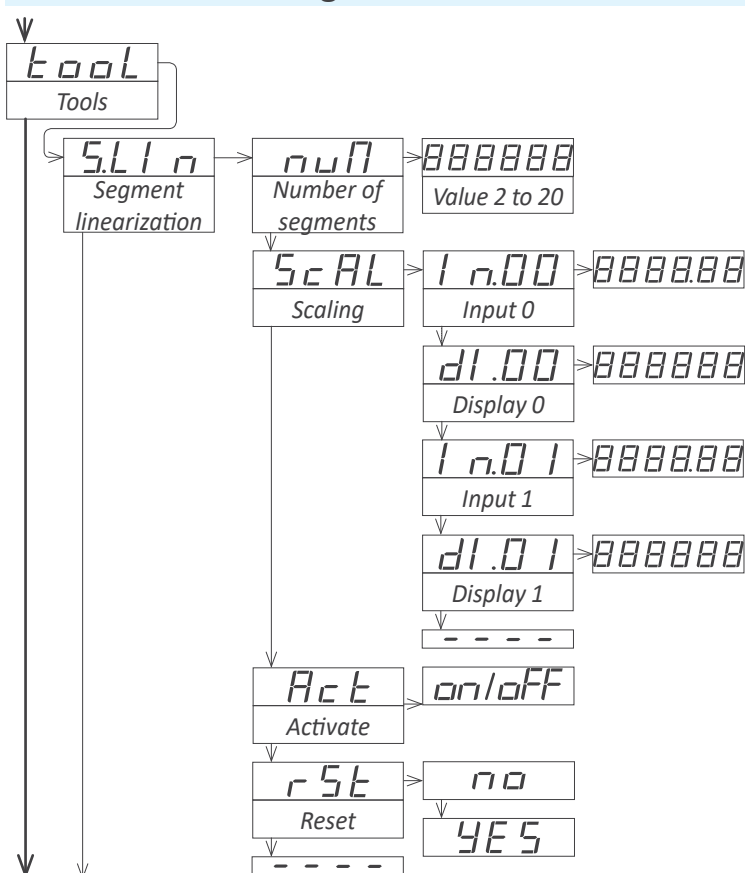

Inside the 'Tools' ('tool') menu several different functions are grouped.

At the 'Segment Linearization' ('S.LIn') define up to 20 segments to linearize non-linear signals. See section 1.12.8 for more information.

- at the 'Number of segment' ('nuM') parameter introduce the number of segments. Value between '2' and '20'.
- at the 'Scaling' ('ScAL') parameter introduce the input signal value ('Input') and the associated reading value ('Display') for each point, starting at point '0', up to the total number of segments previously defined..
- select 'Activate' ('Act') to 'on' to activate the segments previously configured. Select 'off' to disable the segment linearization and return to standard scaling (see section 1.12.2)
- select 'Reset' ('rSt') to 'YES' deletes the actual segment linearization.

1.12.11 Fast access

The *'fast access'* is an operator configurable menu. The operator can access this menu with a single press of the front key 'UP' (▲). The configured menu entries will be accessible. Eligible parameters to be accessed by this menu are:

- access to the alarm setpoints through the 'UP' (▲) key allows to read and modify the values.
- access to the maximum and minimum alarms through the 'UP' (▲) key allows to read and reset the values. To reset the memory values: visualize the value on display, press the 'UP' (▲) key, when the 'rSt' message appears, press 'SQ' (■). The instrument will return to the memory visualization. Press the 'LE' (◀) key to exit his menu.
- access to the 'tare' parameter through the 'UP' (▲) key allows to visualize the value (in display counts) of the tare applied (see section 1.12.14).
- access to the 'measure' function through the 'UP' (▲) key visualizes the actual signal at input terminals, without scaling, directly in mA or Vdc value. The 'measure' function pro-

vides a direct 'voltmeter' or 'miliammeter' integrated into the instrument, to be used for troubleshooting. It helps to easily confirm if the received signal is correct or not.

The *'fast access'* menu is not affected by the password function. This means that the configuration menu can be password blocked, while some configured functions or parameters can still be accessible to the operator through the *'fast access'* menu.

• **Super fast access**

If only a single function is selected for the *'fast access'* menu, pressing the the 'UP' (▲) key will shortly display the function name and then automatically jump to the function value.

1.12.12 'on power up' function

The **'On Power Up'** ('on.Pu') functions allows to define a series of actions to activate when the instrument restarts after a power loss. Functions available are a delay so the instrument waits a defined time before starting to measure and control, and an automatic tare of the reading. The functions will apply only after a restart due to power-loss, they will not apply after a restart due to changes in configuration.

Delaying the measure and control functions gives additional time to elements of the system who are slower, so they can start completely before the instrument begins to acquire signal and control the outputs.

While on delay mode, the instrument shows all decimal points lightened and flashing, all alarms are deactivated, and there is no signal acquisition or communications control. When the delay time is over, the instrument starts its normal functioning.

1.12.13 'LE' key

The 'LE' (◀) key at the front of the instrument can be configured to activate several functions. Only one function can be assigned to the 'LE' (◀) key. Eligible functions are the 'tare' function (see section 1.12.14) and the alarm unlock function (see section 1.12.4).

1.12.14 'Tare' function

The **'Tare function'** ('tArE') allows to use the instrument with weight applications. The tare function assigns the actual input signal value to a display of '0', by means of an internal offset. The scaling of the instrument is not modified, only additional counts are added to the offset.

The tare function is accessible through the front 'LE' (◀) key (see section 1.12.13). The actual value of the tare is accessible through the front 'UP' (▲) key (see section 1.12.11). To reset the tare to '0' counts activate the 'reset' parameter of the 'tare' menu

1.12.15 Excitation voltage

The **'Excitation Volt'** ('V.EXC') allows to select the excitation voltage value to 5 Vdc, 10 Vdc, 15 Vdc or 20 Vdc. Select 'oFF' to disable the excitation voltage.

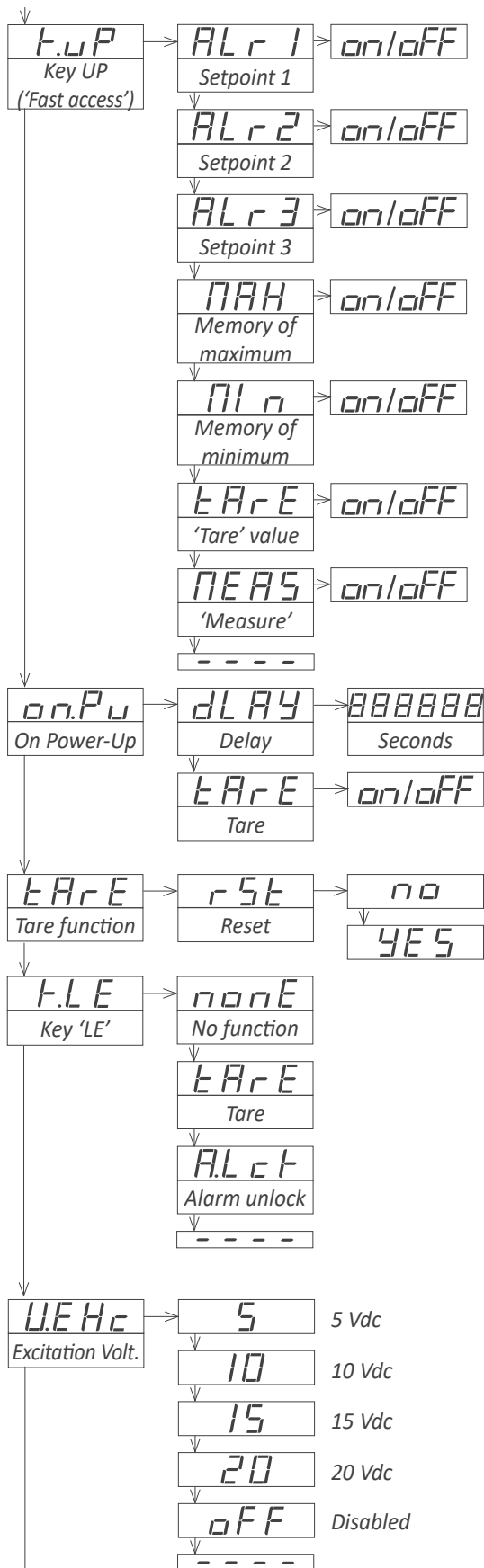

At the **'Key UP ('fast access') ('K.uP')** menu configure which functions and parameters will be accessible through the 'fast access' menu. Select **'on'** to activate each function. For more information see section 1.12.11.

- the **'Setpoint 1' ('ALr1')** function allows to visualize and modify the alarm 1 setpoint through the 'fast access' menu.
- the **'Setpoint 2' ('ALr2')** function allows to visualize and modify the alarm 2 setpoint through the 'fast access' menu.
- the **'Setpoint 3' ('ALr3')** function allows to visualize and modify the alarm 3 setpoint through the 'fast access' menu.
- the **'Memory of maximum' ('MAX')** or **'Memory of minimum' ('MIn')** functions allow to visualize the maximum or minimum reading value stored in memory.
- the **'tare value' ('tArE')** allows to visualize the value of the applied tare.
- the **'Measure' ('MEAS')** function allows to visualize the actual input signal in mA or Vdc, without scaling.

The **'On Power Up' ('on.Pu')** menu assigns functions to be applied when the instrument starts after a power loss. For more information see section 1.12.12.

- at the **'Delay' ('dLAY')** parameter configure the time the instrument will wait before starting normal functionality. Time between 0 and 200 seconds.
- at the **'tare function' ('tArE')** parameter select **'on'** to activate an automatic tare every time the instrument starts after a power loss..
- the **'Tare' ('tArE')** allows to reset the value of the tare. See section 1.12.14 for more information on the 'tare' function..

The **'LE' (◀)** key at the front of the instrument can be configured to activate several functions. For more information see section 1.12.13.

- the **'No function' ('nonE')** parameter assigns no function.
- the **'Tare' ('tArE')** parameter assigns the tare function.
- the **'Alarm unlock' ('A.Lck')** parameter assigns the manual alarm unlocking, when the **'Locked alarms' ('A.Lck')** is active (see section 1.12.4).

At the **'Excitation Volt.' ('V.Exc')** menu select the excitation voltage of the instrument. For more information see section 1.12.15.

1.12.16 Password configuration

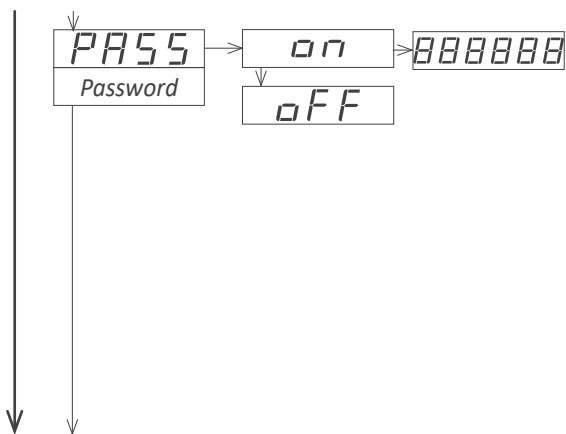

The password function blocks access to the configuration menu. The 'fast access' menu is not affected by the password function. This means that the configuration menu can be password blocked, while some configured functions or parameters can still be accessible to the operator through the 'fast access' menu.

To activate the 'Password' function select 'on' and introduce the 6 digits code. The code will be requested when trying to access the 'configuration menu' (front key 'SQ' (■)).

1.12.17 Default factory configuration

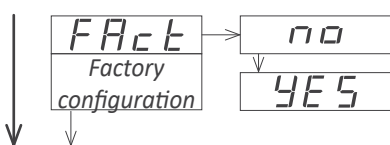

At the 'Factory configuration' ('FACT') menu select 'yes' to activate the default factory configuration. See section 1.13 for a list of default parameters.

1.12.18 Firmware version

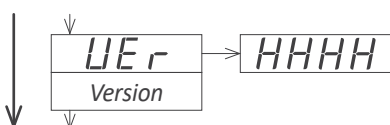

The 'Version' ('VER') menu informs about the firmware version installed on the instrument.

1.12.19 Brightness configuration

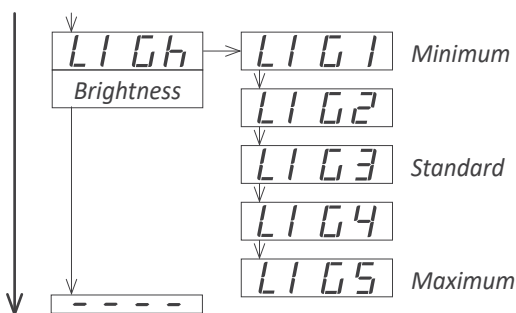

At the 'Brightness' ('LIGH') menu select the intensity level for the display . Use this function to adapt the brightness to match other instruments in the vicinity or to the darkness or clarity of your environment.

1.12.20 Access to the options configuration menu

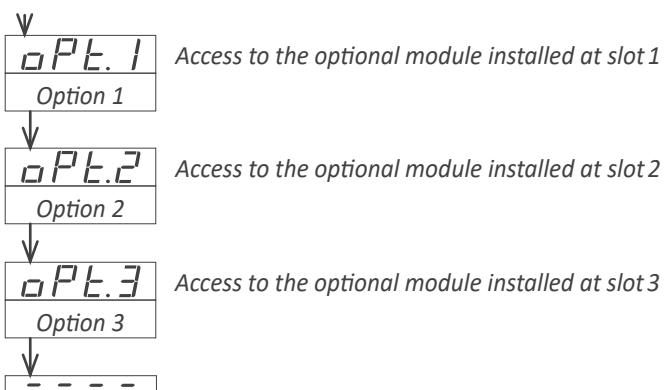

The output and control options are optional modules that can be installed at the instrument. Formats B24 and B44 have 2 free slots for output and control options, while formats B26 and B46 have 3 free slots (see section 1.4).

Several of these optional modules have their own configuration menu embedded. The 'OPT.1', 'OPT.2' and 'OPT.3' menu entries give access to the configuration menu of the option installed.

See section 2 for a list of available output and control modules

1.13 Factory configuration

Range	4/20 mA
Scaling and decimal point	4/20 mA = 0/100.0
Alarms 1,2 and 3	
Active	off (disabled)
Type	as maximum
Setpoint	1000
Hysteresis	0 counts
Activation delay	0.0 seconds
Deactivation delay	0.0 seconds
Setpoint 2	off
Inverted relay	off
Locked alarms	off
Display	
Fixed digits	off
Average	off
'Steps'	off
Left zeros	off
Maximum memory	-199999
Minimum memory	999999
'Peak&Hold'	off
Tools	
Segment linearization	off
Fast access	off
'On Power Up'	
Delay	0 seconds
Tare	off
Ley 'LE'	no function
Excitation voltage	+20 Vdc
Password	off
Brightness	3

1.14 Messages and errors

Error messages are informed flashing on display (examples for 6 digit formats).

<i>Messages and errors</i>	
'h.ldr' 'h.ovr'	hardware underrange ('h.ldr') / overrange ('h.ovr'). Input signal is lower / higher than the minimum / maximum signal the instrument can detect.
'd.ldr' 'd.ovr'	display underrange ('d.ldr') / overrange ('d.ovr'). The display is displaying the maximum / minimum value possible (-199999 / 999999).
'hoLd'	the ' hold ' function is active. Display is on hold.
'P.hLd'	the ' Peak&Hold ' function is active.
'Err.0'*	at the ' scaling ' ('ScAL') menu entry, the defined slope is higher than '5000' (slope almost vertical) or higher than 10000 for 6 digit formats. Default values are activated. *Slope= [(dHl-dLo)/(lHl-lLo)]
'Err.1'	incorrect password.
'Err.2'	when accessing an ' oPt.X ' menu entry, the installed module can not be recognized.
'Err.3'	at ' segment linearization ' ('SLin') menu entry, the input signal values are not in growing succession.
'Err.5'*	at the ' segment linearization ' ('SLin') menu entry, the defined slope of one segment is higher than '5000' (slope almost vertical) or higher than 10000 for 6 digit formats. *Slope= [(dHl-dLo)/(lHl-lLo)]
'Err.8'	excitation voltage overload.

Table 12 - Messages and error codes

1.15 Full configuration menu

Press 'SQ' (■) for 1 second to access the 'Configuration menu'.

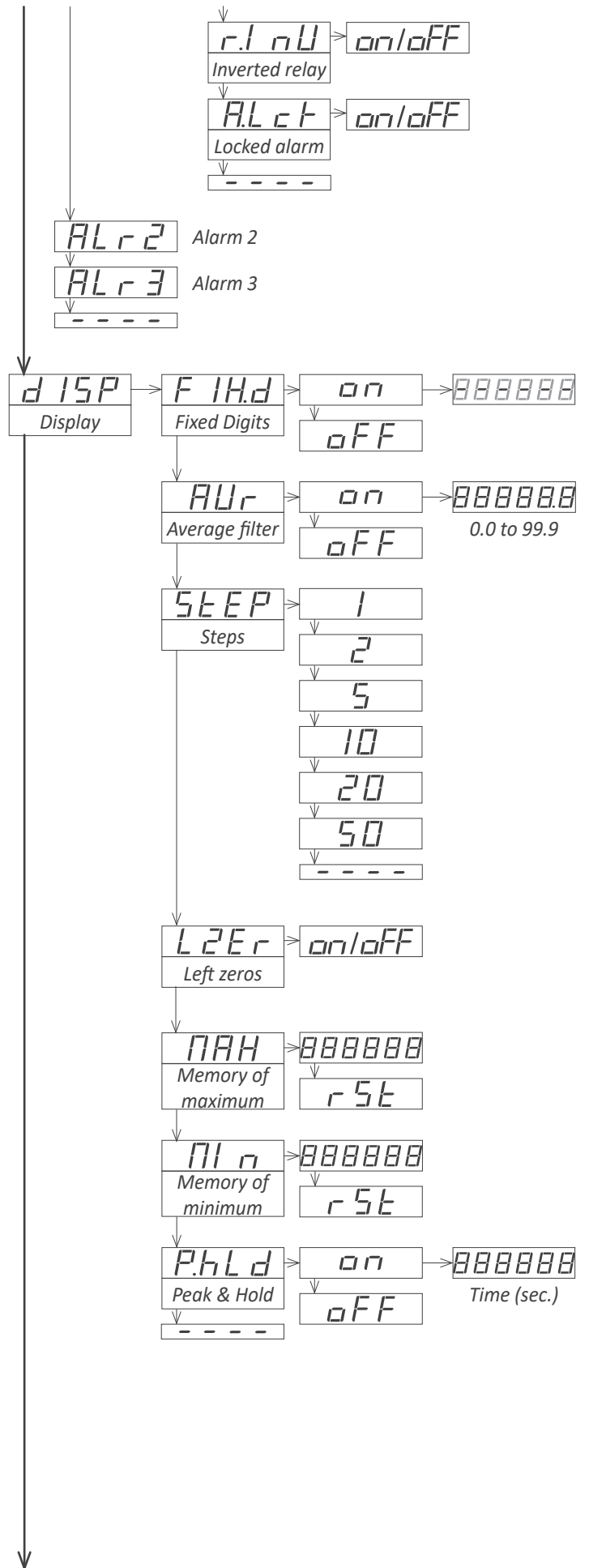
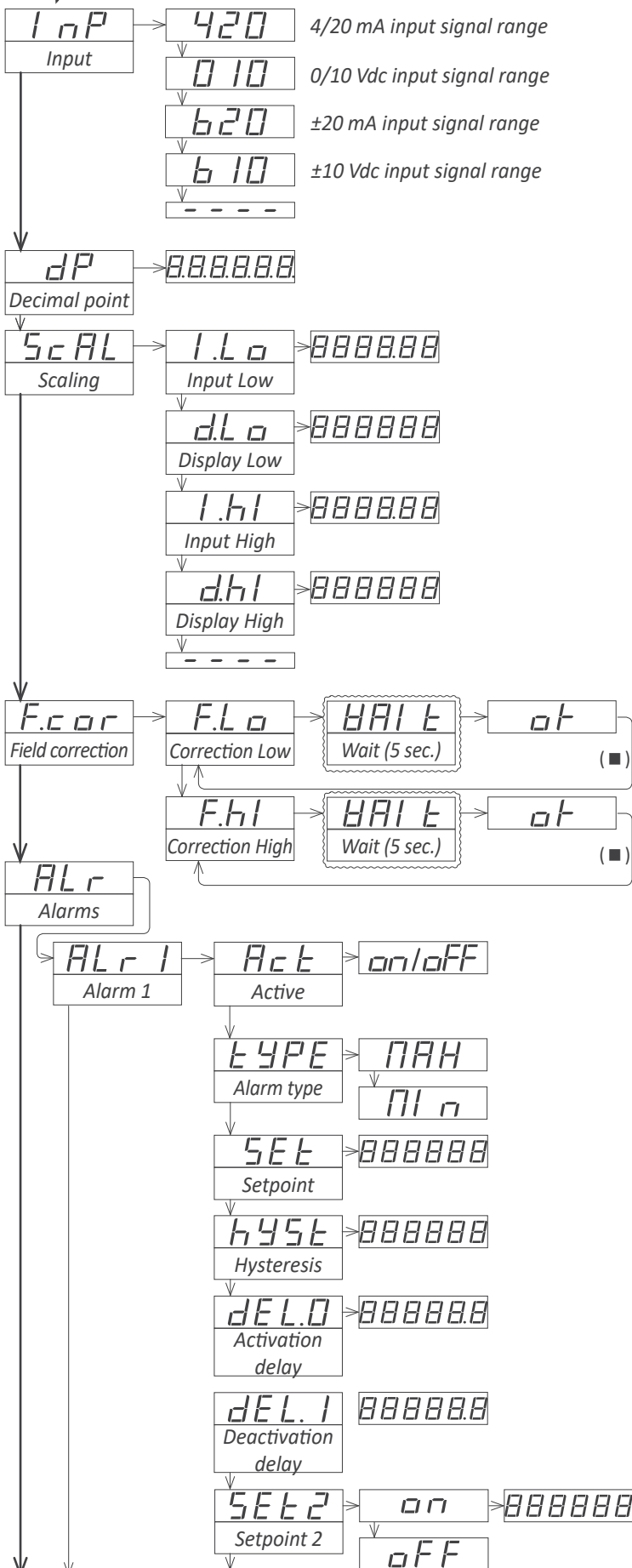

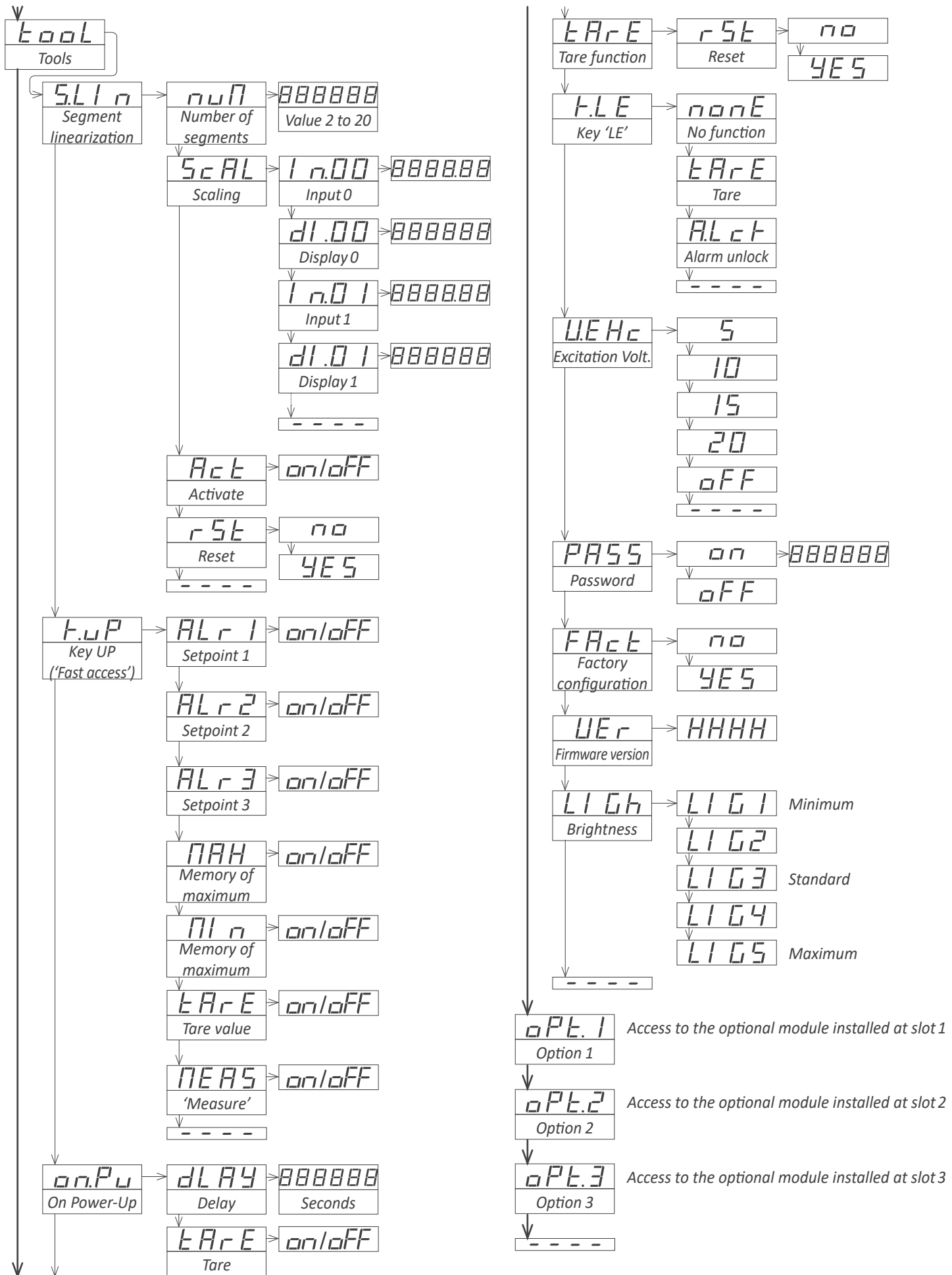

1.16 Mounting

The instrument fixations are designed to allow panel mount, wall mount, or hanging mount. For each type of mounting,

- Panel mount. Apply the cut-out to the panel as seen on section 1.4. Remove the side fixations. Introduce the instrument into the panel cut-out. Mount the side fixations as shown (see Figure 12). Slightly loosen the fixation screw of one side and press the instrument against the panel. Tighten the fixation screw so it presses the panel and maintains the fixation. Repeat with the opposite side fixation.

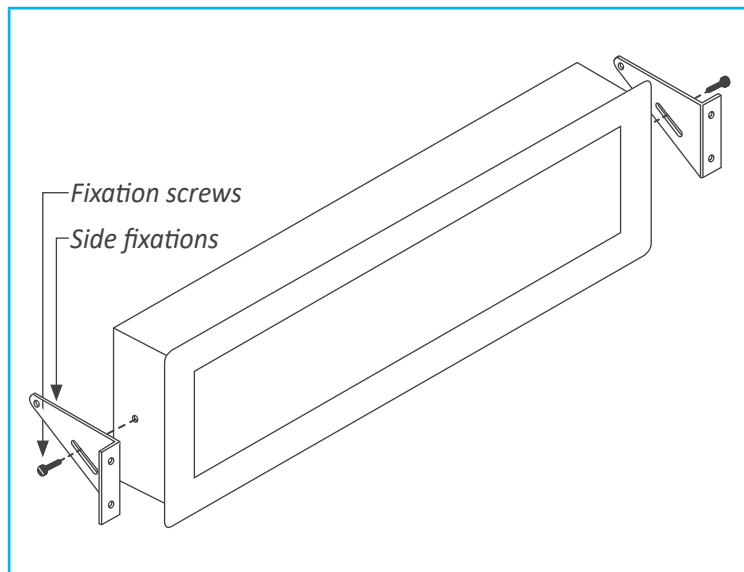

Figure 12 - Panel mount

see the position of the fixations at the images below.

- Wall mount. Mount the side fixations against the wall, as shown (see Figure 14). Each fixation has 2 holes with 4,5 mm diameter and a separation between hole centers of 30 mm. Once the side fixations are secured against the wall, place the instrument and press the fixation screws slightly. Tilt the instrument to the desired viewing angle and firmly screw the fixation screws.

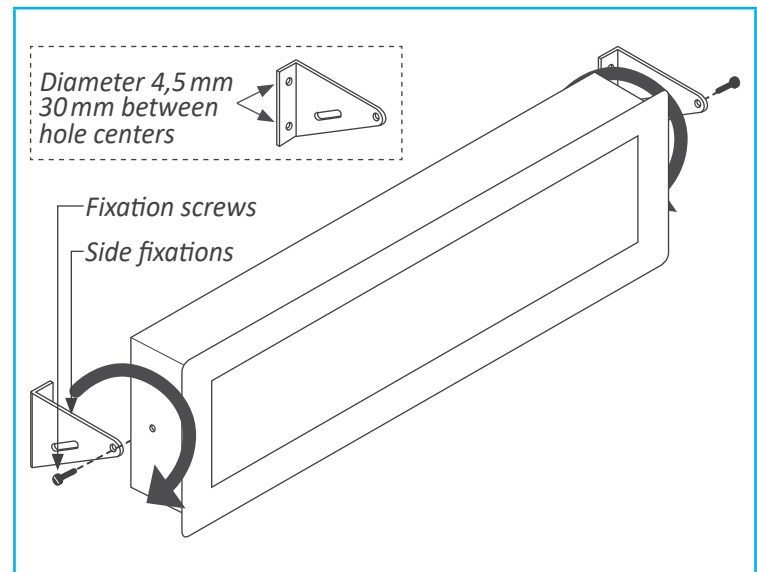

Figure 14 - Wall mount

- Hanging mount. Mount the side fixations as shown (see Figure 13). Each fixation has 2 holes with 4,5 mm diameter and a separation between hole centers of 30 mm. Instrument can be hanged using cable, threaded rod,

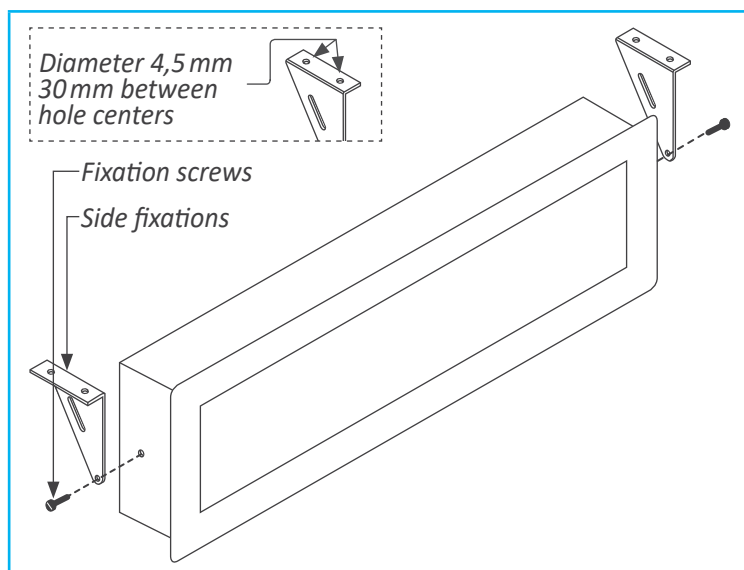

Figure 13 - Hanging mount

1.17 Installation precautions



Risk of electrical shock. Instrument terminals can be connected to dangerous voltage.



Instrument conforms to CE rules and regulations.

This instrument has been designed and verified conforming to the 61010-1 CE security regulation, for industrial applications. Installation of this instrument must be performed by qualified personnel only. This manual contains the appropriate information for the installation. Using the instrument in ways not specified by the manufacturer may lead to a reduction of the specified protection level. Disconnect the instrument from power before starting any maintenance and / or installation action. The instrument does not have a general switch and will start operation as soon as power is connected. The instrument does not have protection fuse, the fuse must be added during installation.

An appropriate ventilation of the instrument must be assured. Do not expose the instrument to excess of humidity. Maintain clean by using a humid rag and do NOT use abrasive products such as alcohols, solvents, etc.

General recommendations for electrical installations apply, and for proper functionality we recommend : if possible, install the instrument far from electrical noise or magnetic field generators such as power relays, electrical motors, speed variators, ... If possible, do not install along the same conduits power cables (power, motor controllers, electrovalves, ...) together with signal and/or control cables.

Before proceeding to the power connection, verify that the voltage level available matches the power levels indicated in the label on the instrument.

In case of fire, disconnect the instrument from the power line, fire alarm according to local rules, disconnect the air conditioning, attack fire with carbonic snow, never with water.

1.18 Warranty

This instrument is warranted against all manufacturing defects for a period of 24 MONTHS from the shipment date. This warranty does not apply in case of misuse, accident or manipulation by non-authorized personnel. In case of malfunction get in contact with your local provider to arrange for repair. Within the warranty period and after examination by the manufacturer, the unit will be repaired or substituted when found to be defective. The scope of this warranty is limited to the repair cost of the instrument, not being the manufacturer eligible for responsibility on additional damages or costs.

1.19 CE declaration of conformity

Manufacturer FEMA ELECTRÓNICA, S.A.
 Altimira 14 - Pol. Ind. Santiga
 E08210 - Barberà del Vallès
 BARCELONA - SPAIN
 www.fema.es - info@fema.es

Products B24-P, B44-P, B26-P, B46-P

The manufacturer declares that the instruments indicated comply with the directives and rules indicated below.

Electromagnetic compatibility directive 2014/30/EU

Low voltage directive 2014/65/EU

Directive ROHS 2011/65/EU

Directive WEEE 2012/19/EU

Security rules EN-61010-1:2010

Instrument Fixed, Permanently connected
 Pollution degree 1 and 2 (without condensation)
 Isolation Basic + Protective union

Electromagnetic compatibility rules EN-61326-1:2013

EM environment Industrial

Immunity levels

EN-61000-4-2	By contact ±4 KV By air ±8 KV	Criteria B Criteria B
EN-61000-4-3		Criteria A
EN-61000-4-4	On AC power lines: ±2 KV On DC power lines: ±2 KV On signal lines : ±1 KV	Criteria B Criteria B Criteria B
EN-61000-4-5	Between AC power lines ±1 KV Between AC power lines and earth ±2 KV Between DC power lines ±1 KV Between DC power lines and earth ±2 KV Between signal lines and earth ±1 KV	Criteria B Criteria B Criteria B Criteria B Criteria B
EN-61000-4-6		Criteria A
EN-61000-4-8	30 A/m at 50/60 Hz	Criteria A
EN-61000-4-11	0 % 1 cycle 40 % 10 cycles 70 % 25 cycles 0 % 250 cycles	Criteria A Criteria A Criteria B Criteria B

Emission levels

CISPR 11 Instrument Class A, Group 1 Criteria A

Barberà del Vallès October 2020
 Xavier Juncà - Product Manager

Declarations available:

CE - www.fema.es/docs/5647_CE-Declaration_B_en.pdf

UK CA - www.fema.es/docs/5653_UKCA-Declaration_B_en.pdf



According to directive 2012/19/EU, electronic equipment must be recycled in a selective and controlled way at the end of its useful life.

2. Output and control modules

2.1 Module R1

The R1 module provides 1 relay output to install in large format industrial meters from Series B. Formats B26 and B46 accept up to 3 relays, and formats B24 and B44 accept up to 2 relays.

Configuration is performed from the front keypad of the instrument, by setting the alarm parameters. Check the alarm menu parameters at the instrument user's manual for full information.

Modules R1 can be provided factory installed into a Series B instrument, or standalone for delayed installation. No soldering or special configuration is required. See section 1.6 on how to install output and control modules.

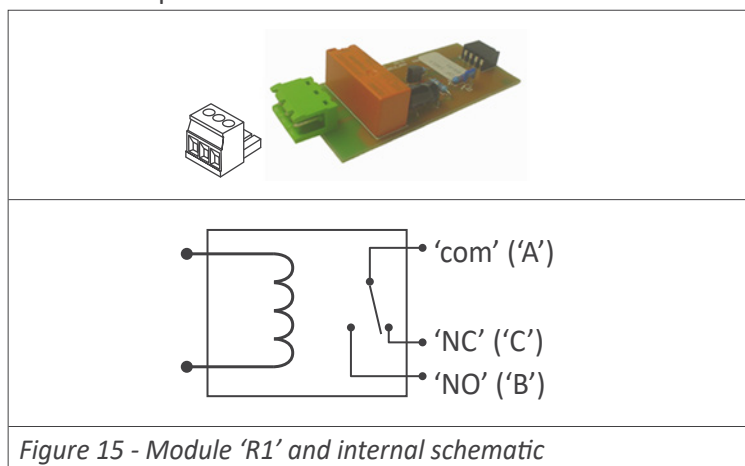

Figure 15 - Module 'R1' and internal schematic

Type of relay	3 contacts (Com, NO, NC)
Max. current	3 A (resistive load)
Voltage	250 Vac continuous
Isolation	3500 Veff
Terminal	plug-in screw clamp, pitch 5.08 mm
Installation allowed at	slot 1, slot 2, slot 3

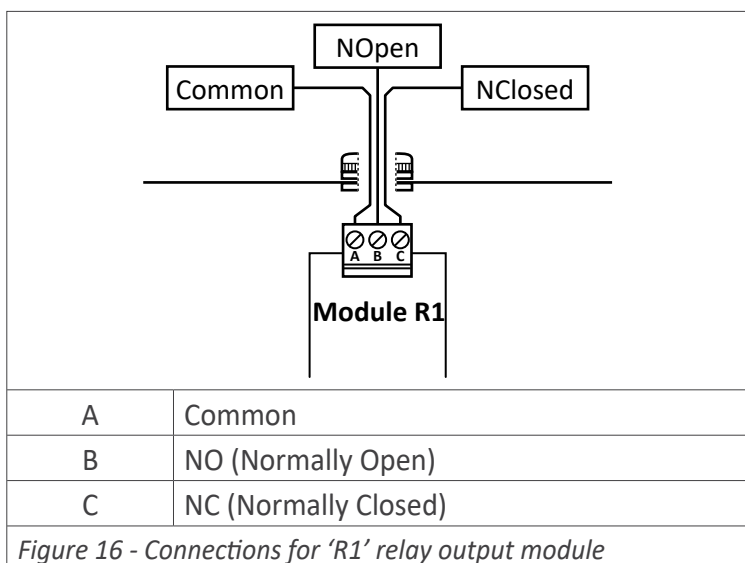

Figure 16 - Connections for 'R1' relay output module

For more information:
http://fema.es/docs/4326_SERIES-B_OPTIONS_manual_en.pdf

2.2 Module T1

The T1 module provides 1 transistor output to install in large format industrial meters from Series B. Formats B26 and B46 accept up to 3 transistor outputs, and formats B24 and B44 accept up to 2 transistor outputs.

Configuration is performed from the front keypad of the instrument, by setting the alarm parameters. Check the alarm menu parameters at the instrument user's manual for full information.

Modules T1 can be provided factory installed into a Series B instrument, or standalone for delayed installation. No soldering or special configuration is required. See section 1.6 on how to install output and control modules.

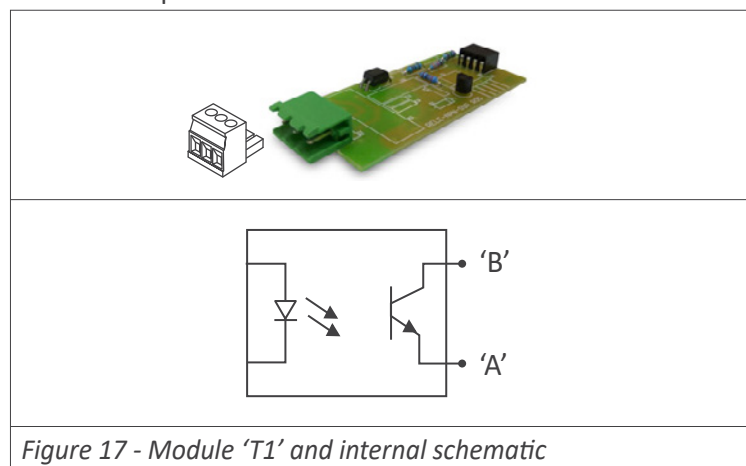

Figure 17 - Module 'T1' and internal schematic

Type of output	transistor
Max. voltage	35 Vdc
Max. current	50 mA
Isolation	3500 Veff, optoisolated
Terminal	plug-in screw clamp, pitch 5.08 mm
Installation allowed at	slot 1, slot 2, slot 3

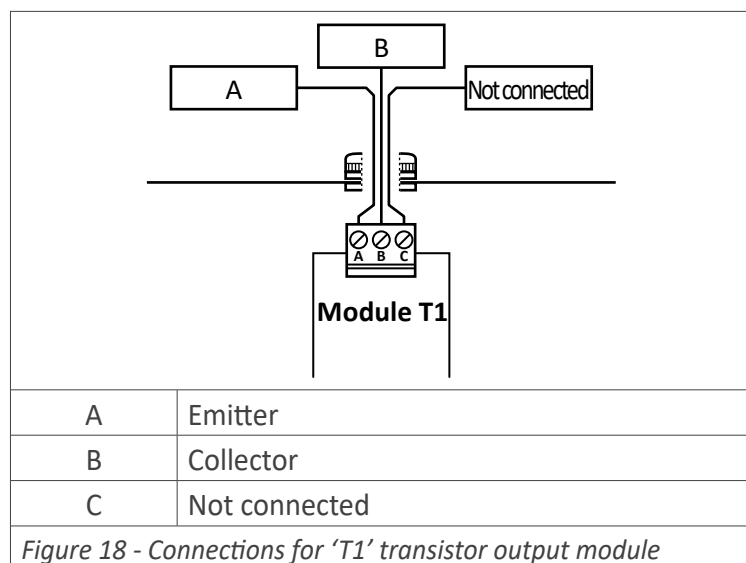

Figure 18 - Connections for 'T1' transistor output module

For more information:
http://fema.es/docs/4326_SERIES-B_OPTIONS_manual_en.pdf

2.3 Module SSR

The SSR module provides 1 output for SSR relay control, to install in large format industrial meters from Series B. Formats B26 and B46 accept up to 3 SSR control outputs, and formats B24 and B44 accept up to 2 SSR control outputs.

Configuration is performed from the front keypad of the instrument, by setting the alarm parameters. Check the alarm menu parameters at the instrument user's manual for full information.

Modules SSR can be provided factory installed into a Series B instrument, or standalone for delayed installation. No soldering or special configuration is required. See section 1.6 on how to install output and control modules.

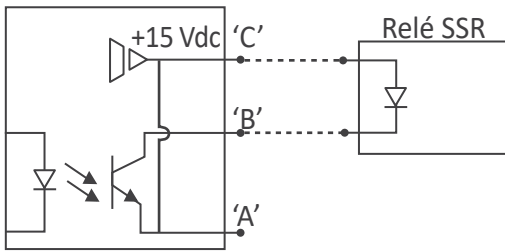
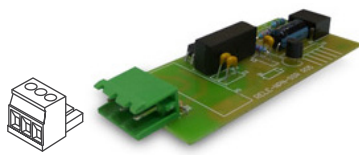
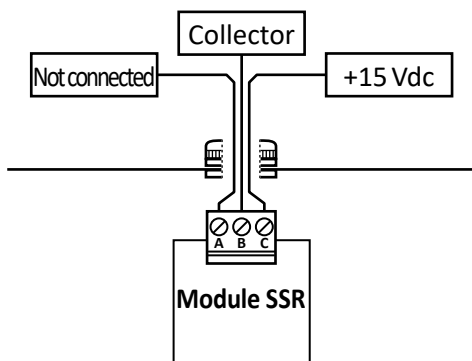

Figure 19 - Module 'SSR' and internal schematic

Type of output	for SSR relay control
Output voltage	+15 Vdc
Max. current	45 mA
Isolation	1000 Vdc
Terminal	plug-in screw clamp, pitch 5.08 mm
Installation allowed at	slot 1, slot 2, slot 3



A	Not connected
B	Collector (-)
C	+15 Vdc (+)

Figure 20 - Connections for 'SSR' control module

For more information:
http://fema.es/docs/4326_SERIES-B_OPTIONS_manual_en.pdf

2.4 Module AO

The AO module provides 1 analog output, configurable for 4/20 mA or 0/10 Vdc signal, to install in large format industrial meters from Series B. Formats B26 and B46 accept up to 3 analog outputs, and formats B24 and B44 accept up to 2 analog outputs.

Output signal is fully scalable, both with positive and negative slopes, and is proportional to the reading. The mA output can be configured for active loops (the instrument provides the power to the mA loop) or passive loops (the loop power is external to the instrument).

Configuration is performed from the front keypad of the instrument, by accessing the menu entries 'Opt.1', 'Opt.2' or 'Opt.3', according to the slot where the module is installed.

AO modules can be provided factory installed into a Series B instrument, or standalone for delayed installation. No soldering or special configuration is required. See section 1.6 on how to install output and control modules.

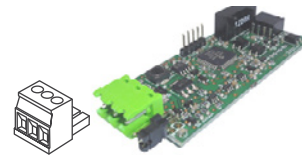
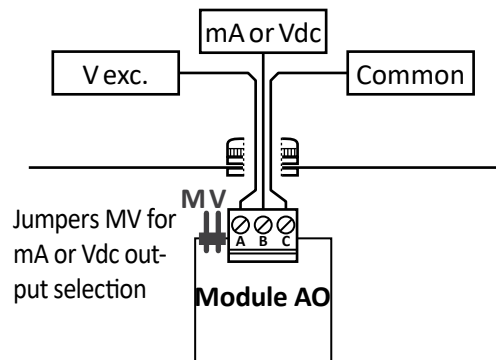

Figure 21 - Module 'AO'

Signal output	4/20mA, 0/10Vdc (active and passive)
Accuracy	0.1% FS
Isolation	1000 Vdc
Terminal	plug-in screw clamp, pitch 5.08 mm
Installation allowed at	slot 1, slot 2, slot 3



A	Excitation voltage
B	Signal in mA or Vdc
C	Common
Jumper M	Jumper closed for mA output
Jumper V	Jumper closed for Vdc output

Figure 22 - Connections for 'AO' analog output module

For more information:
http://fema.es/docs/4326_SERIES-B_OPTIONS_manual_en.pdf

2.5 Module RTU

The RTU module provides an isolated Modbus RTU communications port, to install in large format industrial meters from Series B.

The RTU module implements function '4' ('Read Input Registers') of the Modbus RTU protocol, to access the instrument registers (reading value, alarm status, memory of maximum and minimum, ...).

Configuration is performed from the front keypad of the instrument, by accessing the menu entries 'Opt.1', 'Opt.2' or 'Opt.3', according to the slot where the module is installed.

Modules RTU can be provided factory installed into a Series B instrument, or standalone for delayed installation. No soldering or special configuration is required. See section 1.6 on how to install output and control modules.

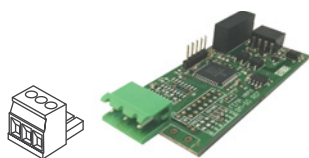
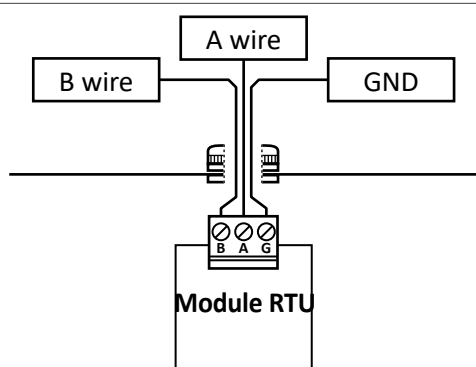

Figure 23 - Communications module 'RTU'

Protocol	Modbus RTU
Bus	RS-485, up to 57.6 Kbps
Isolation	1000 Vdc
Terminal	plug-in screw clamp, pitch 5.08 mm
Installation allowed at	slot 1, slot 2, slot 3



A	Bus signal A
B	Bus signal B
G	GND

Figure 24 - Connections for Modbus 'RTU' communications module

For more information:
http://fema.es/docs/4326_SERIES-B_OPTIONS_manual_en.pdf

2.6 Module S4

The S4 module provides an isolated RS-485 ASCII communications port, to install in large format industrial meters from Series B.

The S4 module implements a MASTER / SLAVE protocol, with up to 31 addressable slaves. In SLAVE mode allows access to reading values, alarm status, memory of maximum and minimum, ...

Configuration is performed from the front keypad of the instrument, by accessing the menu entries 'Opt.1', 'Opt.2' or 'Opt.3', according to the slot where the module is installed.

Modules S4 can be provided factory installed into a Series B instrument, or standalone for delayed installation. No soldering or special configuration is required. See section 1.6 on how to install output and control modules.

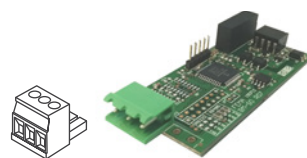
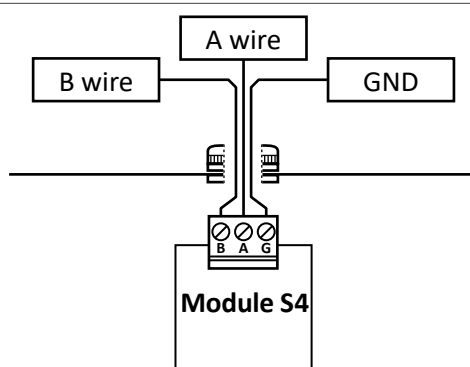

Figure 25 - Communications module 'S4'

Protocol	ASCII
Bus	RS-485, up to 57.6 Kbps
Isolation	1000 Vdc
Terminal	plug-in screw clamp, pitch 5.08 mm
Installation allowed at	slot 1, slot 2, slot 3



A	Bus signal A
B	Bus signal B
G	GND

Figure 26 - Connections for RS-485 'S4' communications module

For more information:
http://fema.es/docs/4326_SERIES-B_OPTIONS_manual_en.pdf

2.7 Module S2

The S2 module provides an isolated RS-232 ASCII communications port, to install in large format industrial meters from Series B.

The S2 module implements a MASTER / SLAVE protocol, with up to 31 addressable slaves, with 'daisy-chain' connection. In SLAVE mode allows access to reading values, alarm status, memory of maximum and minimum, ...

Configuration is performed from the front keypad of the instrument, by accessing the menu entries 'Opt.1', 'Opt.2' or 'Opt.3', according to the slot where the module is installed.

Modules S2 can be provided factory installed into a Series B instrument, or standalone for delayed installation. No soldering or special configuration is required. See section 1.6 on how to install output and control modules.

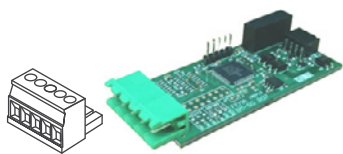
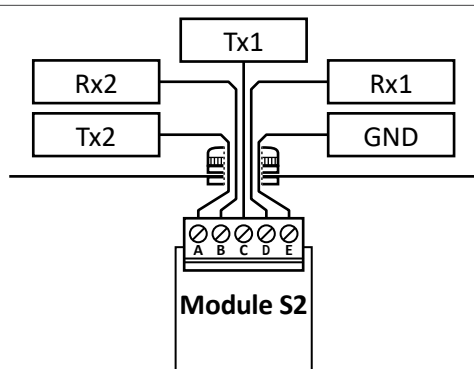

Figure 27 - Communications module Module 'S2'

Protocol	ASCII
Bus	RS-232, up to 57.6 Kbps
Isolation	1000 Vdc
Terminal	plug-in screw clamp, pitch 5.08 mm
Installation allowed at	slot 1, slot 2, slot 3



A	'Daisy chain' Tx data transmission
B	'Daisy chain' Rx data reception
C	Tx data transmission
D	Rx data reception
E	GND

Figure 28 - Connections for RS-232 'S2' communications module

For more information:

http://fema.es/docs/4326_SERIES-B_OPTIONS_manual_en.pdf

3. Other options and accessories

3.1 RKB - Remote keypad

Remote keypad for large format industrial meters from Series B. Replicates a remote version of the front keypad, close to the operator.

(*Cable not provided).



3.2 Red LED

Red LED



3.3 Green LED

Green LED



Empty page

Empty page

Empty page



DIGITAL PANEL METERS
 Section Industrial



SIGNAL CONVERTERS
 Section Industrial



LARGE DISPLAYS
 Section Industrial



PANEL METERS . LOW COST
 Section OEM



CONVERTERS . ISOLATORS
 Section OEM



LARGE DISPLAYS
 Section Special



SPECIAL INSTRUMENTS
 Section Special



DATA ACQUISITION
 Section Industrial



'CUSTOMIZED' INSTRUMENTS